

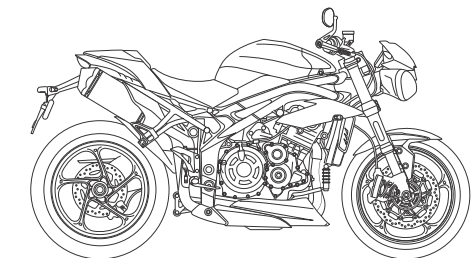

Owner's Handbook

Speed Triple S and Speed Triple RS

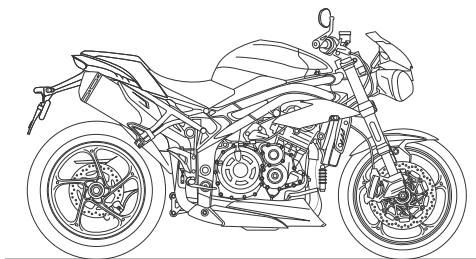

This handbook contains information on the Triumph Speed Triple S and Speed Triple RS motorcycles. Always store this Owner's Handbook with the motorcycle and refer to it for information whenever necessary.

The information contained in this publication is based on the latest information available at the time of printing. Triumph reserves the right to make changes at any time without prior notice, or obligation.

Not to be reproduced wholly or in part without the written permission of Triumph Motorcycles Limited.

© Copyright 11.2017 Triumph Motorcycles Limited, Hinckley, Leicestershire, England.

Publication part number 3855531-EN issue 1

TABLE OF CONTENTS

This handbook contains a number of different sections. The table of contents below will help you find the beginning of each section where, in the case of the major sections, a further table of contents will help you find the specific subject required.

Foreword.....	3
Safety First.....	5
Warning Labels.....	10
Parts Identification.....	12
Serial Numbers.....	15
General Information.....	16
How to Ride the Motorcycle.....	76
Accessories, Loading and Passengers.....	89
Maintenance.....	93
Cleaning and Storage.....	143
Specifications.....	152
Index.....	156
Smart Keyless System Approval Addendum.....	160

FOREWORD

Warnings, Cautions and Notes

Throughout this Owner's Handbook particularly important information is presented in the following form:

 Warning
This warning symbol identifies special instructions or procedures, which if not correctly followed could result in personal injury, or loss of life.

 Caution
This caution symbol identifies special instructions or procedures, which, if not strictly observed, could result in damage to, or destruction of, equipment.

Note:

- **This note symbol indicates points of particular interest for more efficient and convenient operation.**

Warning Labels



At certain areas of the motorcycle, the symbol (above) can be seen. The symbol means 'CAUTION: REFER TO THE HANDBOOK' and will be followed by a pictorial representation of the subject concerned.

Never attempt to ride the motorcycle or make any adjustments without reference to the relevant instructions contained in this Owner's Handbook.

For more information on the location of all warning labels, see page **10**. Where necessary, this symbol will also appear on the pages containing the relevant information.

Maintenance

To ensure a long, safe and trouble free life for your motorcycle, maintenance should only be carried out by an authorised Triumph dealer.

Only an authorised Triumph dealer will have the necessary knowledge, equipment and skills to maintain your Triumph motorcycle correctly.

To locate your nearest authorised Triumph dealer, visit the Triumph web site at www.triumph.co.uk or telephone the authorised distributor in your country. Their address is given in the service record book that accompanies this handbook.

Tyres

With reference to the Pneumatic Tyres and Tubes for Automotive Vehicles (Quality Control) Order, 2009, Cl. No. 3 (c), it is declared by M/s. Triumph Motorcycles Ltd. that the tyres fitted on this motorcycle meet the requirements of IS 15627: 2005 and comply with the requirements under Central Motor Vehicle Rules (CMVR), 1989.

Owner's Handbook

Warning

This Owner's Handbook, and all other instructions that are supplied with your motorcycle, should be considered a permanent part of your motorcycle and should remain with it even if your motorcycle is subsequently sold.

All riders must read this Owner's Handbook and all other instructions which are supplied with your motorcycle, before riding, in order to become thoroughly familiar with the correct operation of your motorcycle's controls, its features, capabilities and limitations. Do not lend your motorcycle to others as riding when not familiar with your motorcycle's controls, features, capabilities and limitations can lead to an accident.

Thank you for choosing a Triumph motorcycle. This motorcycle is the product of Triumph's use of proven engineering, exhaustive testing, and continuous striving for superior reliability, safety and performance.

Please read this Owner's Handbook before riding in order to become thoroughly familiar with the correct operation of your motorcycle's controls, its features, capabilities and limitations.

This handbook includes safe riding tips, but does not contain all the techniques and skills necessary to ride a motorcycle safely.

Triumph strongly recommends that all riders undertake the necessary training to ensure safe operation of this motorcycle.

This handbook is available from your local dealer in:

- English
- US English
- French
- German
- Italian
- Dutch
- Spanish
- Portuguese
- Swedish
- Japanese

Talk to Triumph

Our relationship with you does not end with the purchase of your Triumph. Your feedback on the buying and ownership experience is very important in helping us develop our products and services for you.

Please help us by ensuring your authorised Triumph dealership has your email address and registers this with us. You will then receive an online customer satisfaction survey invitation to your email address where you can give us this feedback.

Your Triumph Team.

SAFETY FIRST

The Motorcycle

Warning

This motorcycle is designed for on-road use only. It is not suitable for off-road use.

Off-road operation could lead to loss of control of the motorcycle resulting in an accident causing injury or loss of life.

Warning

This motorcycle is not designed to tow a trailer or be fitted with a sidecar. Fitting a sidecar and/or a trailer may result in loss of control and an accident.

Warning

This motorcycle is designed for use as a two-wheeled vehicle capable of carrying a rider on his/her own, or a rider and one passenger.

The total weight of the rider, and any passenger, accessories and luggage must not exceed the maximum load limit of 196 kg (432 lbs).

Fuel and Exhaust Fumes

Warning

PETROL IS HIGHLY FLAMMABLE:

Always turn off the engine when refuelling.

Do not refuel or open the fuel filler cap while smoking or in the vicinity of any open (naked) flame.

Take care not to spill any petrol on the engine, exhaust pipes or silencers when refuelling.

If petrol is swallowed, inhaled or allowed to get into the eyes, seek immediate medical attention.

Spillage on the skin should be immediately washed off with soap and water and clothing contaminated with petrol should immediately be removed.

Burns and other serious skin conditions may result from contact with petrol.

Warning

Never start your engine or let it run for any length of time in a closed area.

The exhaust fumes are poisonous and may cause loss of consciousness and death within a short time.

Always operate your motorcycle in the open-air or in an area with adequate ventilation.

Safety First

Helmet and Clothing

Warning



When riding the motorcycle, both rider and passenger (on models where carrying a passenger is permitted) must always wear a motorcycle helmet, eye protection, gloves, boots, trousers (close fitting around the knee and ankle) and a brightly coloured jacket.

Brightly coloured clothing will considerably increase a rider's (or passenger's) visibility to other operators of road vehicles.

Although full protection is not possible, wearing correct protective clothing can reduce the risk of injury when riding.

Warning

A helmet is one of the most important pieces of riding gear as it offers protection against head injuries. You and your passenger's helmet should be carefully chosen and should fit you or your passenger's head comfortably and securely. A brightly coloured helmet will increase a rider's (or passenger's) visibility to other operators of road vehicles.

An open face helmet offers some protection in an accident though a full face helmet will offer more.

Always wear a visor or approved goggles to help vision and to protect your eyes.

Parking

Warning

Always switch off the engine and remove the ignition key before leaving the motorcycle unattended. By removing the key, the risk of use of the motorcycle by unauthorised or untrained persons is reduced.

When parking the motorcycle, always remember the following:

- Engage first gear to help prevent the motorcycle from rolling off the stand.
- The engine and exhaust system will be hot after riding. DO NOT park where pedestrians, animals and/or children are likely to touch the motorcycle.
- Do not park on soft ground or on a steeply inclined surface. Parking under these conditions may cause the motorcycle to fall over.

For further details, please refer to the 'How to Ride the Motorcycle' section of this Owner's Handbook.

Parts and Accessories

Warning

Owners should be aware that the only approved parts, accessories and conversions for any Triumph motorcycle are those which carry official Triumph approval and are fitted to the motorcycle by an authorised dealer.

In particular, it is extremely hazardous to fit or replace parts or accessories whose fitting requires the dismantling of, or addition to, either the electrical or fuel systems and any such modification could cause a safety hazard.

The fitting of any non-approved parts, accessories or conversions may adversely affect the handling, stability or other aspect of the motorcycle operation that may result in an accident causing injury or death.

Triumph does not accept any liability whatsoever for defects caused by the fitting of non-approved parts, accessories or conversions or the fitting of any approved parts, accessories or conversions by non-approved personnel.

Maintenance/Equipment

Warning

Consult your authorised Triumph dealer whenever there is doubt as to the correct or safe operation of this Triumph motorcycle.

Remember that continued operation of an incorrectly performing motorcycle may aggravate a fault and may also compromise safety.

Warning

Make sure all equipment that is required by law is installed and functioning correctly.

The removal or alteration of the motorcycle's lights, silencers, emission or noise control systems can violate the law.

Incorrect or improper modification may adversely affect the handling, stability or other aspect of the motorcycle operation, which may result in an accident causing injury or death.

Warning

If the motorcycle is involved in an accident, collision or fall, it must be taken to an authorised Triumph dealer for inspection and repair.

Any accident can cause damage to the motorcycle that, if not correctly repaired, may cause a second accident that may result in injury or death.

Safety First

Riding

Warning

Never ride the motorcycle when fatigued or under the influence of alcohol or other drugs.

Riding when under the influence of alcohol or other drugs is illegal.

Riding when fatigued or under the influence of alcohol or other drugs reduces the rider's ability to maintain control of the motorcycle and may lead to loss of control and an accident.

Warning

All riders must be licenced to operate the motorcycle. Operation of the motorcycle without a licence is illegal and could lead to prosecution.

Operation of the motorcycle without formal training in the correct riding techniques that are necessary to become licenced is dangerous and may lead to loss of motorcycle control and an accident.

Warning

Always ride defensively and wear the protective equipment mentioned elsewhere in this foreword. Remember, in an accident, a motorcycle does not give the same impact protection as a car.

Warning

This Triumph motorcycle should be operated within the legal speed limits for the particular road travelled. Operating a motorcycle at high speeds can be potentially dangerous since the time available to react to given traffic situations is greatly reduced as road speed increases. Always reduce speed in potentially hazardous driving conditions such as bad weather or heavy traffic.

Warning

Continually observe and react to changes in road surface, traffic and wind conditions. All two-wheeled vehicles are subject to external forces which may cause an accident. These forces include but are not limited to:

- Wind draft from passing vehicles
- Potholes, uneven or damaged road surfaces
- Bad weather
- Rider error.

Always operate the motorcycle at moderate speed and away from heavy traffic until you have become thoroughly familiar with its handling and operating characteristics. Never exceed the legal speed limit.

Handlebars and Footrests

! Warning

The rider must maintain control of the vehicle by keeping hands on the handlebars at all times.

The handling and stability of a motorcycle will be adversely affected if the rider removes his hands from the handlebars, resulting in loss of motorcycle control and an accident.

! Warning

The rider and passenger must always use the footrests provided, during operation of the vehicle.

By using the footrests, both rider and passenger will reduce the risk of inadvertent contact with any motorcycle components and will also reduce the risk of injury from entrapment of clothing.

! Warning

The bank angle indicators must not be used as a guide to how far the motorcycle may be safely banked.

This depends on many various conditions including, but not limited to, road surface, tyre condition and weather.

Banking to an unsafe angle may cause instability, loss of motorcycle control and an accident.

! Warning

Use of a motorcycle with the bank angle indicator worn beyond the maximum limit (when 5 mm of the bank indicator remains) will allow the motorcycle to be banked to an unsafe angle.

Banking to an unsafe angle may cause instability, loss of motorcycle control and an accident.

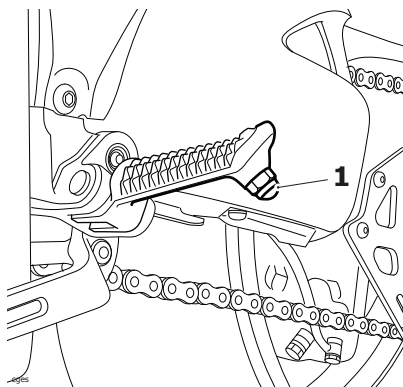

1. Bank angle indicator

Warning Labels

WARNING LABELS

Warning Label Locations

The labels detailed on this and the following pages draw your attention to important safety information in this handbook. Before riding, make sure that all riders have understood and complied with all the information to which these labels relate.

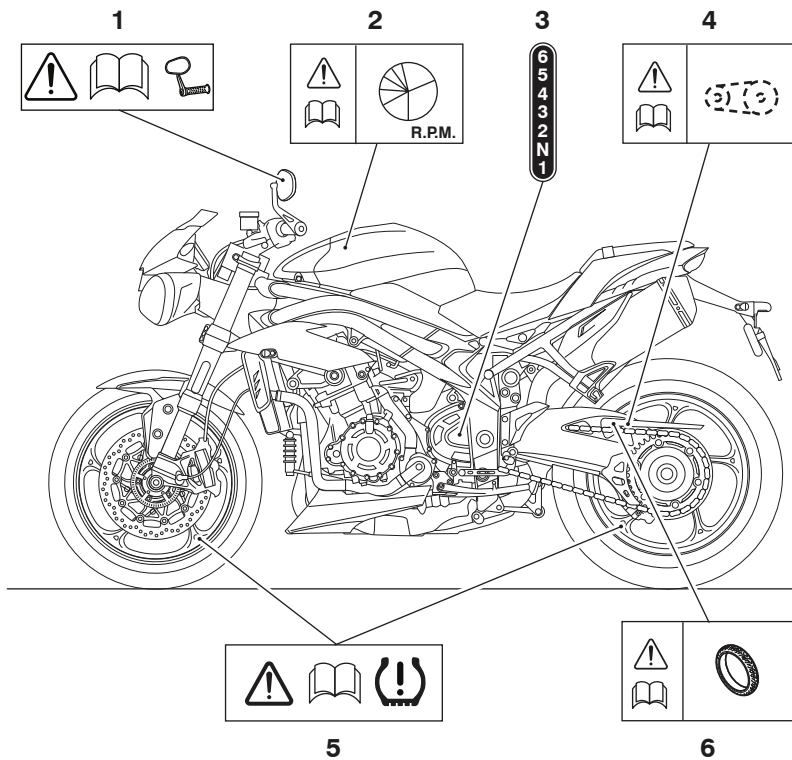

1. Mirrors (page 116)
2. Running-in (page 74)
3. Gears (page 80)
4. Drive Chain (page 108)

5. Tyre Pressure Monitoring System (TPMS) (if fitted) (page 64)
6. Tyres (page 127)

Warning Label Locations (continued)

! Caution

All warning labels and decals, with the exception of the Running-in label, are fitted to the motorcycle using a strong adhesive. In some cases, labels are installed prior to an application of paint lacquer. Therefore, any attempt to remove the warning labels will cause damage to the paintwork or bodywork.

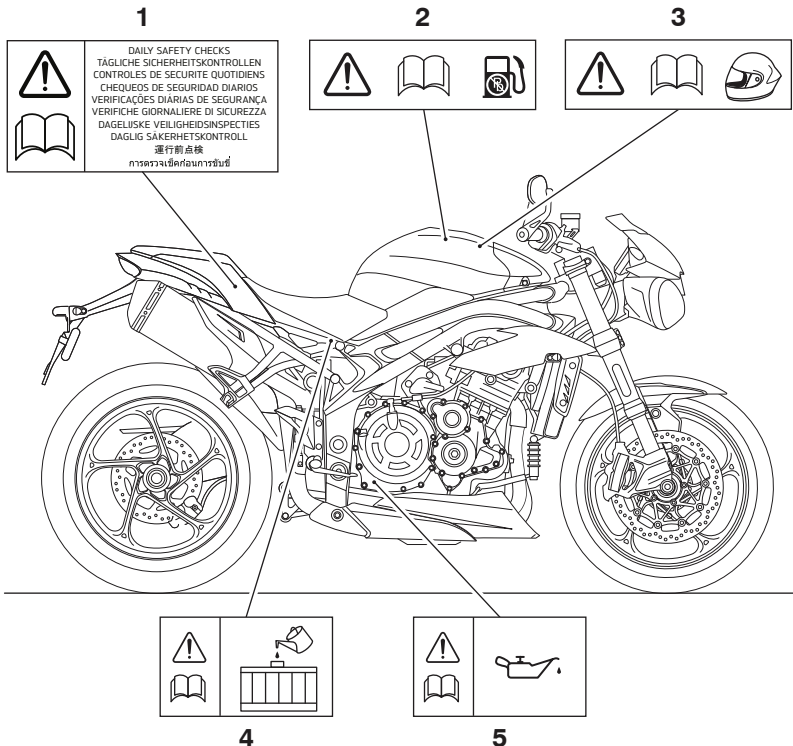

1. Daily Safety Checks (page 75)
2. Fuel (page 67)
3. Helmet (page 6)

4. Coolant (page 102)
5. Engine Oil (page 99)

Parts Identification

PARTS IDENTIFICATION

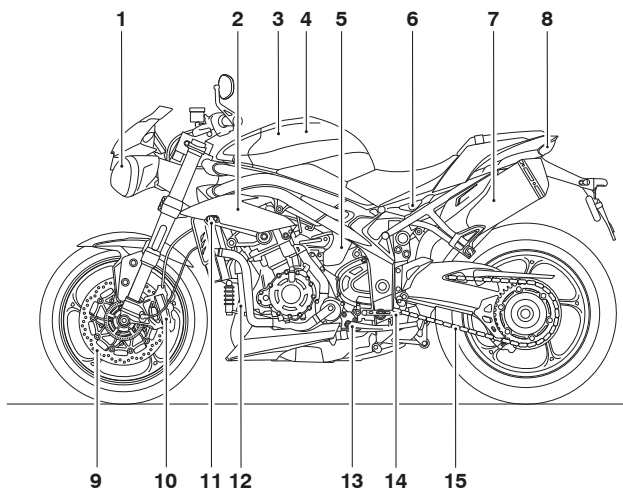

- | | |
|----------------------------------|-------------------------|
| 1. Headlight | 9. Front brake disc |
| 2. Radiator/Coolant pressure cap | 10. Front brake caliper |
| 3. Fuel filler cap | 11. Front indicator |
| 4. Fuel tank | 12. Oil cooler |
| 5. Coolant expansion tank | 13. Side stand |
| 6. Seat lock | 14. Gear change pedal |
| 7. Silencer | 15. Drive chain |
| 8. Rear light | |

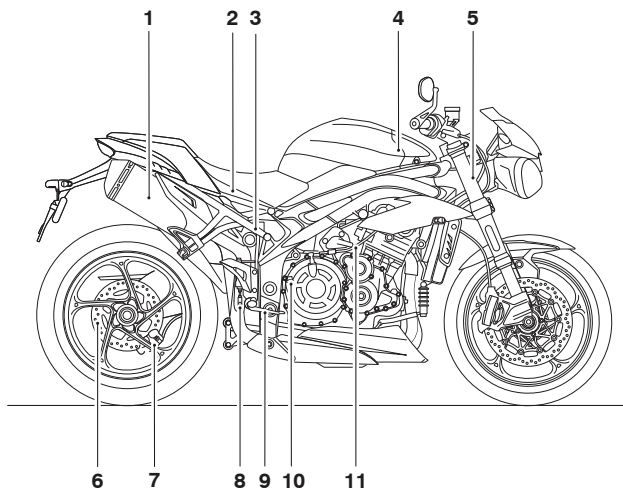

- | | |
|-------------------------------|-----------------------------|
| 1. Silencer | 7. Rear brake caliper |
| 2. Tool kit | 8. Rear suspension unit |
| 3. Rear brake fluid reservoir | 9. Rear brake pedal |
| 4. Battery | 10. Oil filler cap/Dipstick |
| 5. Front fork | 11. Clutch cable |
| 6. Rear brake disc | |

Parts Identification

Rider View Parts Identification

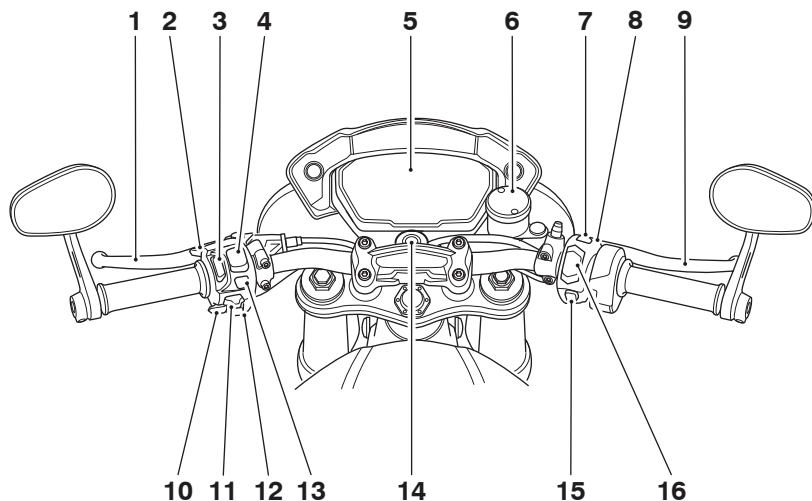

- | | |
|--|---|
| 1. Clutch lever | 9. Front brake lever |
| 2. High beam button | 10. Horn button |
| 3. Daytime Running Lights (DRL) switch (if fitted) | 11. Direction indicator switch |
| 4. Cruise control | 12. Joystick button |
| 5. Instrument display | 13. MODE button |
| 6. Front brake fluid reservoir | 14. Ignition switch (Speed Triple S only) |
| 7. Hazard button | 15. HOME button |
| 8. Steering lock button (Speed Triple RS only) | 16. Engine start/stop switch |

SERIAL NUMBERS

Vehicle Identification Number (VIN)

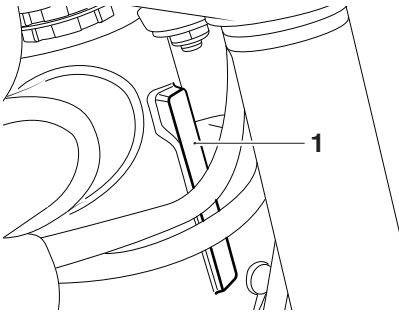

1. Vehicle identification number

The Vehicle Identification Number (VIN) is stamped into the right hand side of the steering head area of the frame.

Record the vehicle identification number in the space provided below.

Engine Serial Number

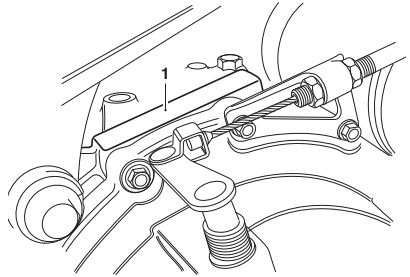

1. Engine serial number

The engine serial number is stamped on the engine crankcase, immediately above the clutch cover.

Record the engine serial number in the space provided below.

General Information

GENERAL INFORMATION

Table of Contents

Instruments	18
Instrument Panel Layout	19
Display Navigation	20
Themes and Styles	20
Warning Lights	20
Speedometer and Odometer	26
Tachometer	26
Gear Position Display	26
Fuel Gauge	27
Service Interval Announcement	27
Ambient Air Temperature	27
Riding Modes	28
Riding Mode Selection	29
Information Tray	31
Main Menu	36
Instrument Panel Position Adjustment	48
Hand Controls	49
Keyless Ignition (if fitted)	49
Master Ignition Switch (if fitted)	51
Ignition Key	51
Ignition Switch/Steering Lock	52
Right Handlebar Switches	53
Right Handlebar Switches	55
Left Handlebar Switches	56
Brake and Clutch Lever Adjusters	58
Throttle Control	60
Cruise Control	61
Activating Cruise Control	62
Adjusting the Set Speed While in Cruise Control	63
Deactivating Cruise Control	63
Resuming the Cruise Control Set Speed	63
Tyre Pressure Monitoring System (TPMS) (if fitted)	64
Tyre Pressures	65
Tyre Pressure Sensor Serial Number	66
Sensor Batteries	66
Replacement Tyres	66

General Information

Fuel	67
Fuel Tank Cap	68
Filling the Fuel Tank	69
Seats	70
Seat Care	70
Seat Lock	70
Passenger Seat Removal	70
Passenger Seat Installation	70
Rider's Seat Removal	71
Rider's Seat Installation	72
Side Stand	72
Universal Serial Bus (USB) Socket	73
Tool Kit and Owner's Handbook	74
Running-In	74
Daily Safety Checks	75

General Information

Instruments

Table of Contents

Instrument Panel Layout.....	19
Display Navigation.....	20
Themes and Styles.....	20
Warning Lights.....	20
Speedometer and Odometer.....	26
Tachometer.....	26
Gear Position Display.....	26
Fuel Gauge.....	27
Service Interval Announcement.....	27
Ambient Air Temperature.....	27
Riding Modes.....	28
Riding Mode Selection.....	29
Information Tray.....	31
Main Menu.....	36
Instrument Panel Position Adjustment.....	48

Instrument Panel Layout

The Thin Film Transistor (TFT) instrument display is fitted on all models. Not all instrument features are available on all models.

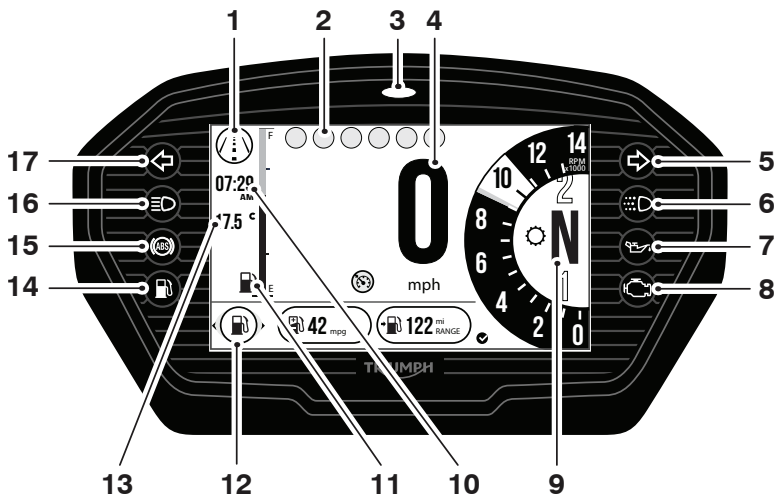

- | | |
|---|----------------------------------|
| 1. Current riding mode | 9. Gear position symbol |
| 2. Warning lights | 10. Clock |
| 3. Alarm/immobiliser status indicator light (alarm is an accessory kit) | 11. Fuel gauge |
| 4. Speedometer | 12. Information tray |
| 5. Right hand indicator | 13. Ambient air temperature |
| 6. Daytime Running Light (DRL) (if fitted) | 14. Fuel level low warning light |
| 7. Oil pressure warning light | 15. ABS warning light |
| 8. Engine management Malfunction Indicator Light (MIL) | 16. High beam warning light |
| | 17. Left hand indicator |

General Information

Display Navigation

The table below describes the instrument icons and buttons used to navigate through the instrument menus described in this handbook.



Home button (right hand switch housing).



Mode button (left hand switch housing).



Joystick left/right or up/down.



Joystick Centre (press).



Selection arrow (right shown).



Information Tray - left/right scroll via joystick.



Information Tray - up/down scroll via joystick.



Option available within the Information Tray - scroll via joystick up/down.



Short press (press and release) via joystick centre.



Long press (press and hold) via joystick centre.



Reset current feature. (only available with joystick long press).

Themes and Styles

There is the option to change the style of the instrument display.

Depending on the motorcycle model, there are either one or two themes. Each theme has three different styles to select from.

To select a theme or style, see page 44.

Styles can also be selected through the Style Options tray, see page 35.

Theme 1, Style 1 is used for visual recognition throughout this owner's handbook.

Theme 1

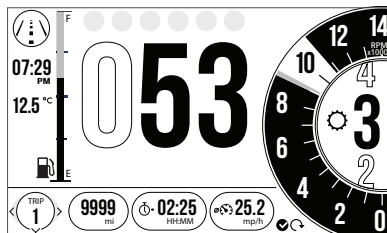

Theme 1 Style 1

Warning Lights

Note:

- When the ignition is switched on, the instrument warning lights will illuminate for 1.5 seconds and will then go off (except those which remain on until the engine starts, as described in the following pages).

For additional warning and information messages, see page 32.

Engine Management System Malfunction Indicator Light (MIL)



The Malfunction Indicator Light (MIL) for the engine management system illuminates when the ignition is switched ON (to indicate that it is working) but should not become illuminated when the engine is running.

If the MIL becomes illuminated when the engine is running, this indicates that a fault has occurred in one or more of the systems controlled by the engine management system. In such circumstances, the engine management system will switch to 'limp-home' mode so that the journey may be completed, if the fault is not so severe that the engine will not run.

Warning

Reduce speed and do not continue to ride for longer than is necessary with the MIL illuminated. The fault may adversely affect engine performance, exhaust emissions and fuel consumption.

Reduced engine performance could cause a dangerous riding condition, leading to loss of control and an accident.

Contact an authorised Triumph dealer as soon as possible to have the fault checked and rectified.

Note:

- If the MIL flashes when the ignition is switched ON contact an authorised Triumph dealer as soon as possible to have the situation rectified. In these circumstances the engine will not start.

Low Oil Pressure Warning Light



With the engine running, if the engine oil pressure becomes dangerously low, the low oil pressure warning light will illuminate.

Caution

Stop the engine immediately if the low oil pressure warning light illuminates. Do not restart the engine until the fault has been rectified.

Severe engine damage will result from running the engine when the low oil pressure warning light is illuminated.

Note:

- **The low oil pressure warning light will illuminate if the ignition is switched ON without running the engine.**

Immobiliser/Alarm Indicator Light

This Triumph motorcycle is fitted with an engine immobiliser which is activated when the ignition is switched off.

General Information

Without Alarm Fitted

When the ignition is switched off, the immobiliser light will flash on and off for 24 hours to show that the engine immobiliser is on. When the ignition is switched on, the immobiliser and the indicator light will be off.

If the indicator light remains on it indicates that the immobiliser has a malfunction that requires investigation. Contact an authorised Triumph dealer as soon as possible to have the fault checked and rectified.

With Alarm Fitted

The immobiliser/alarm light will only illuminate when the conditions described in the genuine Triumph accessory alarm instructions are met.

ABS (Anti-Lock Brake System) Warning Light



When the ignition is switched on, it is normal that the ABS warning light will flash on and off. The light will continue to flash after engine start-up until the motorcycle first reaches a speed exceeding 6 mph (10 km/h) when it will go off.

Note:

- **Traction control will not function if there is a malfunction with the ABS. The warning lights for the ABS, traction control and the MIL will be illuminated.**

The warning light should not illuminate again until the engine is restarted unless there is a fault, or the ABS is switched off - the warning light will remain illuminated.

If the warning light becomes illuminated at any other time while riding it indicates that the ABS has a malfunction that requires investigation.

Warning

If the ABS is not functioning, the brake system will continue to function as a non-ABS equipped brake system. Do not continue to ride for longer than is necessary with the warning light illuminated. Contact an authorised Triumph dealer as soon as possible to have the fault checked and rectified. In this situation braking too hard will cause the wheels to lock resulting in loss of motorcycle control and an accident.

Traction Control (TC) Indicator Light



The TC indicator light is used to indicate that the traction control system is active and is working to limit rear wheel slip during periods of hard acceleration or under wet or slippery road conditions.

Warning

If the traction control is not functioning, care must be taken when accelerating and cornering on wet/slippery road surfaces to avoid rear wheel spin. Do not continue to ride for longer than is necessary with the Engine Management System Malfunction Indicator Light (MIL) and traction control warning lights illuminated. Contact an authorised Triumph dealer as soon as possible to have the fault checked.

Hard acceleration and cornering in this situation may cause the rear wheel to spin resulting in loss of motorcycle control and an accident.

TC Indicator Light Operation:

TC Switched On:

- Under normal riding conditions the indicator light will remain off.
- The indicator light will flash rapidly when the traction control system is working to limit rear wheel slip during periods of hard acceleration or under wet or slippery road conditions.

TC Switched Off:

The indicator light will not illuminate. Instead the TC disabled warning light will be illuminated (see page 23).

Note:

- **Traction control will not function if there is a malfunction with the ABS system. The warning lights for the ABS, traction control and the MIL will be illuminated.**

Traction Control (TC) Disabled Warning Light



The TC disabled warning light should not illuminate unless traction control is switched off or there is a malfunction.

If the warning light becomes illuminated at any other time while riding, it indicates that the traction control system has a malfunction that requires investigation.

Cruise Control Light



The cruise control can only be activated when the motorcycle is travelling at a speed between 19 to 100 mph (30 to 160 km/h) and is in 3rd gear or higher. When activated, the cruise control light will be illuminated.

Warning

Cruise control must only be used where you can ride safely at a steady speed.

Cruise control should not be used when riding in heavy traffic, on roads with sharp/blind bends or when they are slippery.

Using cruise control in heavy traffic, on roads with sharp/blind bends or when they are slippery, may result in loss of motorcycle control and an accident.

General Information

Direction Indicators



When the indicator switch is turned to the left or right, the indicator warning light will flash on and off at the same speed as the direction indicators.

Hazard Warning Lights

To turn the hazard warning lights on or off, press and release the hazard warning light switch.

The ignition must be switched ON for the hazard warning lights to function.

The hazard warning lights will remain on if the ignition is switched off, until the hazard warning light switch is pressed again.

High Beam Button



When the high beam button is pressed the high beam will be switched on. Each press of the button will swap between dip and high beam.

Note:

- **If daytime running lights are fitted to the motorcycle, the high beam button has additional functionality.**

If the DRL switch is in the daytime running lights position, then press and hold the high beam button to turn the high beam on. It will remain on as long as the button is held in and will turn off as soon as the button is released.

Note:

- **A lighting on/off switch is not fitted to this model. The rear light and licence plate light all function automatically when the ignition is on.**
- **The headlight will function when the ignition is on. The headlight will go off while pressing the starter button until the engine starts.**

Daytime Running Lights (DRL)



When the ignition is switched ON and the daytime running lights switch is set to DAYTIME RUNNING LIGHTS, the daytime running lights warning light will illuminate.

The daytime running lights and low beam headlights are operated manually using a switch on the left hand switch housing, see page 56.

Warning

Do not ride for longer than necessary in poor ambient light conditions with the Daytime Running Lights (DRL) in use.

Riding with the Daytime Running Lights when dark, in tunnels or where poor ambient light is apparent may reduce the riders vision or dazzle other road users.

Dazzling other road users or reduced vision in low ambient light levels may result in loss of motorcycle control and an accident.

Note:

- During daylight hours the Daytime Running Lights improve the motorcyclist's visibility to other road users.
- Low beam headlights must be used in any other conditions unless the road conditions allow for high beam headlights to be used.

Low Fuel Warning Light



The low fuel warning light will illuminate when there are approximately 3.5 litres of fuel remaining in the tank.

Tyre Pressure Monitoring System (TPMS) Warning Light (if fitted)



Warning

Stop the motorcycle if the Tyre Pressure Monitoring System (TPMS) warning light illuminates red.

Do not ride the motorcycle until the tyres have been checked and the tyre pressures are at their recommended pressure when cold.

Note:

- The Tyre Pressure Monitoring System (TPMS) is available as an accessory option on some models.



The TPMS warning light will only illuminate red when the front or rear tyre pressure is below the recommended pressure, or no signal is received. It will not illuminate if the tyre is over inflated. For more information, see page 64.

When the warning light is illuminated, the TPMS symbol indicating which is the deflated tyre and its pressure will automatically be visible in the display area.

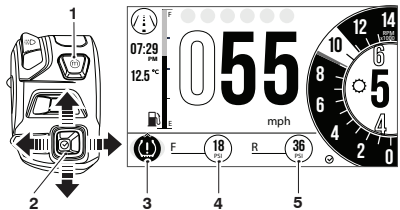

1. Mode button
2. Joystick control
3. TPMS light
4. Front tyre indicator
5. Rear tyre indicator

The tyre pressure at which the warning light illuminates is temperature compensated to 20°C but the numeric pressure display associated with it is not, see page 127. Even if the numeric display seems at or close to the standard tyre pressure when the warning light is on, a low tyre pressure is indicated and a puncture is the most likely cause.

General Information

Speedometer and Odometer

The speedometer indicates the road speed of the motorcycle.

The odometer shows the total distance that the motorcycle has travelled.

Tachometer

⚠ Caution

Never allow engine speed to enter the red zone as severe engine damage may result.

The tachometer shows the engine speed in revolutions per minute - rpm (r/min). At the end of the tachometer range there is the red zone.

Engine speeds in the red zone are above maximum recommended engine speed and are also above the range for best performance.

Gear Position Display

The gear position display indicates which gear (one to six) has been engaged. When the transmission is in neutral (no gear selected), the display will show N.

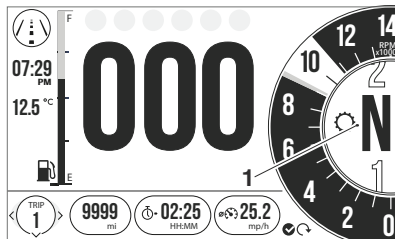

1. Gear position display (neutral position shown)

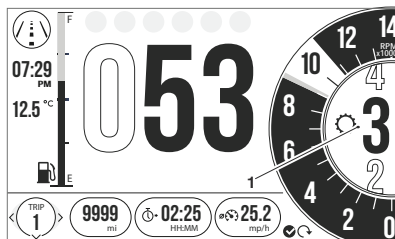

1. Gear position display (third gear shown)

Fuel Gauge

The fuel gauge indicates the amount of fuel in the tank.

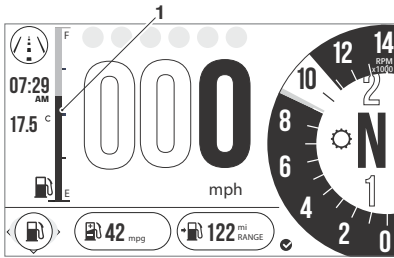

1. Fuel gauge

With the ignition switched on, a filled line indicates the fuel remaining in the fuel tank.

Note:

- **The fuel gauge colours may vary depending on the theme or style chosen.**

The gauge markings indicate intermediate fuel levels between E (empty) and F (full).

The low fuel warning light will illuminate when approximately 3.5 litres of fuel is remaining in the tank and you should refuel at the earliest opportunity.

The range to empty and instantaneous fuel consumption will be also shown in the information tray. Press the joystick centre to acknowledge and hide the low fuel warning.

After refuelling, the fuel gauge and range to empty information will be updated only while riding the motorcycle. Depending on the riding style, updating could take up to five minutes.

Service Interval Announcement



The service interval announcement shows the total distance or time that the motorcycle has remaining before a service is required. When the remaining distance is 0 miles (0 km), or the remaining time is 0 days, the service symbol will remain on until the service has been carried out and the system has been reset by your authorised Triumph dealer.

If the service is overdue then OVERDUE will be shown and the service symbol will be shown in the information tray.

When the service has been carried out by your authorised Triumph dealer, the system will be reset.

The distance to the next service or OVERDUE message will also be shown on the instrument start up screen when the ignition is turned on.

The service symbol will also be shown if a fault has occurred and the ABS and/or MIL warning lights are illuminated. Contact an authorised Triumph dealer as soon as possible to have the fault checked and rectified.

Ambient Air Temperature

The ambient air temperature is displayed as either °C or °F.

When the motorcycle is stationary the heat of the engine may affect the accuracy of the ambient temperature display.

Once the motorcycle starts moving the display will return to normal after a short time.

To change the temperature from °C or °F see page 46.

General Information

Frost Symbol



The frost symbol will illuminate if the ambient air temperature is 4°C (39°F) or lower.

The frost symbol will remain illuminated until the temperature rises to 6°C (42°F).

An alert will also be displayed in the information tray.



CAUTION: LOW AIR TEMPERATURE
RISK OF SURFACE ICE
1/3 warnings



ACKNOWLEDGE

When the motorcycle is stationary the heat of the engine may affect the accuracy of the ambient temperature display.

Once the motorcycle starts moving the display will return to normal after a short time.

Warning

Black ice (sometimes called clear ice) can form at temperatures several degrees above freezing (0°C (32°F)), especially on bridges and in shaded areas.

Always take extra care when the temperatures are low and reduce speed in potentially hazardous driving conditions such as bad weather.

Excess speed, hard acceleration, heavy braking or hard cornering when roads are slippery may result in loss of motorcycle control and an accident.

Riding Modes









The riding modes allow adjustment of the throttle response (MAP), Anti-lock Brake System (ABS) and Traction Control (TC) settings to suit differing road conditions and rider preferences.

Riding modes can be conveniently selected using the MODE button and joystick located on the left hand switch housing, whilst the motorcycle is stationary or moving, see page 29.

Note:

- Up to five riding modes are available depending on the motorcycle model's specification.

If a riding mode is edited (other than the RIDER mode), the icon will change as shown below.

Default Icon	Rider Edited Icon	Description
		RAIN
		ROAD
		SPORT
		TRACK (Speed Triple RS only)
	-	RIDER

Each riding mode is adjustable. For more information, see page 38.

Availability of the ABS, MAP and TC setting options vary between models.

Riding Mode Selection

Warning

The selection of riding modes whilst the motorcycle is in motion requires the rider to allow the motorcycle to coast (motorcycle moving, engine running, throttle closed, clutch lever pulled in and no brakes applied) for a brief period of time.

Riding mode selection whilst the motorcycle is in motion should only be attempted:

- At low speed
- In traffic-free areas
- On straight and level roads or surfaces
- In good road and weather conditions
- Where it is safe to allow the motorcycle to briefly coast.

Riding mode selection whilst the motorcycle is in motion **MUST NOT** be attempted:

- At high speeds
- Whilst riding in traffic
- During cornering or on winding roads or surfaces
- On steeply inclined roads or surfaces
- In poor road/weather conditions
- Where it is unsafe to allow the motorcycle to coast.

Failure to observe this important warning may lead to loss of motorcycle control and an accident.

Warning

If ABS and/or Traction Control (TC) has been disabled in the Main Menu as described on page **40** for ABS and/or page **41** for TC then settings saved for all riding modes will be overridden.

ABS and/or TC will remain off regardless of your riding mode selection until they have been re-enabled or, the ignition has been switched off then on again, or the MODE button is held in to return to the default ROAD mode (which enables ABS and/or TC when the motorcycle is next stationary).

If the ABS is disabled, the brake system will function as a non-ABS equipped braking system. In this situation braking too hard will cause the wheels to lock, and may result in loss of motorcycle control and an accident.

If the traction control is disabled, the motorcycle will handle as normal but without traction control. In this situation accelerating too hard on wet/slippery road surfaces may cause the rear wheel to slip, and may result in loss of motorcycle control and an accident.

Warning

After selecting a riding mode, operate the motorcycle in an area free from traffic to gain familiarity with the new settings.

Do not loan your motorcycle to anyone as they may change the riding mode settings from the one you are familiar with, causing loss of motorcycle control and an accident.

General Information

Note:

- The riding mode will default to ROAD when the ignition is switched on, if the RIDER mode was active the last time the ignition was switched off with ABS or TC set to OFF in either of those modes.
- Otherwise, the last selected riding mode will be remembered and activated when the ignition is switched on.
- If the mode icons are not shown when the ignition is switched on, then make sure that the engine stop switch is in the RUN position.

The current riding mode is shown in the upper left of the display screen.

To select a riding mode:

- Press and release the MODE button on the left hand switch housing to activate the riding mode selection tray at the bottom of the display screen.
- The currently active riding mode icon is highlighted with a blue background.

To change the selected riding mode:

- Either push the joystick left or right, or repeatedly press the MODE button until the required mode is in the centre of the display screen, highlighted with an arrow above it.
- A brief press of the joystick centre will select the required riding mode, and the icon in the upper left of the display screen will change.

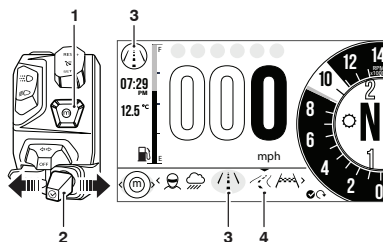

1. **MODE button**
2. **Joystick**
3. **Current riding mode**
4. **New riding mode**

- Push the joystick left/right or press the MODE button to scroll through the riding mode options in the following order:
 - RIDER
 - RAIN
 - ROAD
 - SPORT
 - TRACK (Speed Triple RS only).

The selected mode is activated once the following conditions for switching modes have been met:

Motorcycle Stationary - Engine Off

- The ignition is switched on
- The engine stop switch is in the RUN position.

Motorcycle Stationary - Engine Running

- Neutral gear is selected or the clutch is pulled in.

Motorcycle in Motion

Within 30 seconds of selecting a riding mode the rider must carry out the following simultaneously:

- Close the throttle
- Pull the clutch in
- Make sure that the brakes are not engaged (allow the motorcycle to coast).

Note:

- **It is not possible to switch into or out of TRACK or RIDER mode whilst the motorcycle is in motion, if the ABS or TC settings are set to TRACK or OFF in either of those modes.**
- **In this case, the motorcycle must be brought to a stop before the riding mode change can take place.**

If a riding mode change is not completed, the icon will alternate between the previous riding mode and the newly selected riding mode until the change is complete or it is cancelled.

The riding mode selection is now complete and normal riding can be resumed.

Information Tray



When the motorcycle is in motion, only attempt to switch between the information tray modes or reset the fuel information under the following conditions:

- At low speed
- In traffic free areas
- On straight and level roads or surfaces
- In good road and weather conditions.

Failure to observe this important warning could lead to loss of motorcycle control and an accident.

The information tray appears at the bottom of the display screen and allows easy access to different motorcycle status information.

To view the different information tray items, push the joystick left/right until the required information tray item is shown.

Note:

- **To access the information tray, the warning messages must first be acknowledged, see page 32.**

General Information

The information tray contains the following information tray items:

- Warnings and Information Messages, see page **32**
- Fuel Information, see page **32**
- Tyre Pressure Monitoring System (TPMS) (if fitted), see page **64**
- Odometer, see page **34**
- Service Interval Announcement, see page **34**
- Screen Contrast, see page **34**
- Style Options, see page **35**
- Coolant Temperature, see page **35**
- Trip Meter, see page **35**

Different information tray items can be shown or hidden from the information tray. For further information, refer to page **45**.

Warnings

Any warnings and information messages are shown in the Warnings tray. An example is shown below.

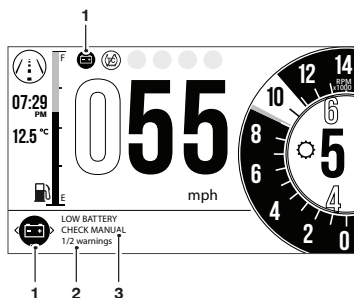

1. **Low battery warning**
2. **Warning counter**
3. **Warning description**

To view the warnings:

- Push the joystick left/right to scroll through the options until the warning review is shown.
- Push the joystick down/up to review each warning (if more than one). The warning counter will show the amount of warnings that are present.
- Push the joystick left/right to return to the information tray.

Low Battery Warning

If items such as heated grips are fitted and are on with the engine at idle, over a period of time, the battery voltage may drop below a predetermined voltage and a warning message will be shown in the Warnings tray.

Fuel Status Information

The Fuel Status information tray shows fuel consumption information.

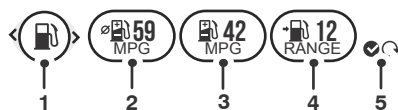

1. **Fuel information light**
2. **Average fuel consumption**
3. **Instantaneous fuel consumption**
4. **Range to empty**
5. **Reset**

Fuel Information Light

This light illuminates when the fuel level warning light is activated.

Average Fuel Consumption

This is an indication of the average fuel consumption. After being reset the display will show dashes until 0.1 miles/km has been covered.

Instantaneous Fuel Consumption

An indication of the fuel consumption at an instant in time. If the motorcycle is stationary, --.- will be shown in the display area.

Range to Empty

This is an indication of the predicted distance that can be travelled on the remaining fuel in the tank.

Reset

To reset the average fuel consumption, press and hold the joystick centre.

Note:

- **After refuelling, the fuel gauge and range to empty information will be updated only while riding the motorcycle. Depending on the riding style, updating could take up to five minutes.**

Tyre Pressure Monitoring System (TPMS) (if fitted)

The Tyre Pressure Monitoring System (TPMS) information tray item shows the front and rear tyre pressures and the TPMS warning light. For more information on TPMS, see page 64.

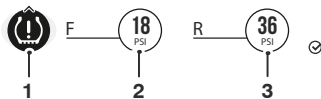

1. TPMS warning light
2. Front tyre pressure display
3. Rear tyre pressure display

TPMS Warning Light

The warning light will only illuminate when the front or rear tyre pressure is below the recommended pressure. It will not illuminate if the tyre is over inflated.

Warning

Stop the motorcycle if the Tyre Pressure Monitoring System (TPMS) warning light illuminates.

Do not ride the motorcycle until the tyres have been checked and the tyre pressures are at their recommended pressure when cold.

General Information

Front Tyre Pressure Display

This shows the current front tyre pressure.

Rear Tyre Pressure Display

This shows the current rear tyre pressure.

Odometer

The odometer shows the total distance that the motorcycle has travelled.

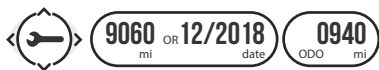

Odometer Information Tray

Service Interval Announcement

The Service Interval Announcement information tray shows the service symbol, the distance/days remaining before the next service and the current odometer reading.

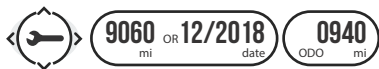

Service Interval Announcement Information Tray

For more information on service interval announcements, see page 27.

Screen Contrast

The Screen Contrast information tray item allows the display screen contrast to be adjusted.



Screen Contrast Information Tray

There are two options available:

- **HIGH CONTRAST** - This option locks the display screen to the white background version of each display screen style for maximum visibility.
- **AUTO CONTRAST** - This option uses the instrument light sensor to adjust the contrast to the most suitable setting. In bright sunlight, low brightness settings will be overridden to make sure that the instruments can be viewed at all times.

To select an option:

- Push the joystick down/up to select either the **HIGH CONTRAST** or **AUTO CONTRAST** option and press the joystick centre to confirm.

If the rider defined brightness setting is suitable this will be used, see page 44.

Note:

- **Do not cover the light sensor on the display screen as this will stop the screen contrast from working correctly.**

Style Options

The Style Options information tray item allows a different style to be applied to the display screen.



Style Options Information Tray (Style 2 Selected)

To change the display screen style:

- Push the joystick down/up to select the required style and then press the joystick centre to confirm.

Coolant Temperature

The Coolant Temperature information tray item indicates the temperature of the engine coolant.



Coolant Temperature Information Tray

When the engine is started from cold the display will show grey bars. As the temperature increases more bars in the display will be shown illuminated. When the engine is started from hot the display will show the relevant number of illuminated bars, dependant on engine temperature.

The range is between C (cold) and H (hot) on the display.

With the engine running, if the engine coolant temperature becomes dangerously high, the high coolant temperature warning light on the display will be illuminated and the gauge will be shown in the information tray.

 **Caution**

Stop the engine immediately if the high coolant temperature warning light illuminates. Do not restart the engine until the fault has been rectified.

Severe engine damage will result from running the engine when the high coolant temperature warning light is illuminated.

Trip Meter

There are two trip meters that can be accessed and reset in the information tray.



Trip Meter Information Tray

To view a specific trip meter:

- Push the joystick left/right to scroll through the information tray items until Trip 1 meter is shown.
- Select TRIP 1 or TRIP 2 by pushing the joystick down/up.

General Information

Note:

- **TRIP 2 meter can be shown or hidden from the information tray. For more information, see page 43.**

To reset a trip meter:

- Select the trip meter to be reset.
- Press and hold the joystick centre for more than one second.
- The trip meter will then be reset.

The trip meter can also be reset from the Main menu, see page 41.

Main Menu

To access the Main menu:

- The motorcycle must be stationary with the ignition switched on.
- Press the HOME button on the right handlebar switch housing.
- Scroll the Main menu by pushing the joystick down/up until the required option is selected and then press the joystick centre to confirm.

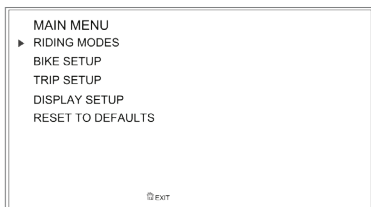

Main Menu Screen

The Main menu allows access to the following options:

Riding Modes

This menu allows configuration of the riding modes. For more information, see page 38.

Bike Set Up

This menu allows configuration of the different features of the motorcycle. For more information, see page 39.

Trip Set Up

This menu allows configuration of Trip 1 and Trip 2. For more information, see page 41.

Display Set Up

This menu allows configuration of the display options. For more information, see page 43.

Reset to Defaults

This menu allows all instrument settings to be returned to the default setting. For more information, see page 48.

Riding Modes Menu

The Riding Modes menu allows configuration of the riding modes.



To access the Riding Modes menu:

- Press the HOME button to display the Main menu.
- Push the joystick down and then press the joystick centre to select RIDING MODES.

The following model specific options are available:

- Rider
- Rain
- Road
- Sport
- Track
- Reset To Defaults.

Riding Modes

To change the riding modes settings:

- From the Riding Modes menu, push the joystick down/up to select a specific riding mode and press the joystick centre to confirm.

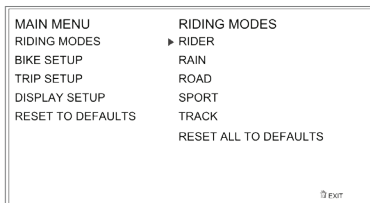

- Push the joystick down/up until the required setting option is selected and press the joystick centre to confirm.

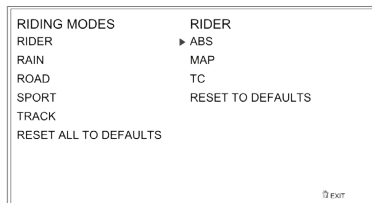



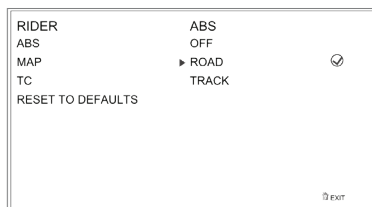

- Push the joystick down/up until the required option is selected and press the joystick centre to confirm.



General Information

Riding Mode Configuration

Refer to the following table for the ABS, MAP and TC options available for each riding mode.

Riding Mode					
	RIDER 	RAIN 	ROAD 	SPORT 	TRACK ¹ 
ABS (Anti-lock Braking System)					
Road	●	●	●	●	○
Track ¹	○	∅	∅	∅	●
Off	○	Via Menu	Via Menu	Via Menu	○
MAP (Throttle Response)					
Rain	○	●	○	∅	○
Road	●	○	●	○	○
Sport	○	∅	○	●	●
TC (Traction Control)					
Rain	○	●	○	∅	○
Road	●	○	●	○	○
Sport	○	∅	○	●	○
Track ¹	○	∅	∅	∅	●
Off	○	Via Menu	Via Menu	Via Menu	○
¹ Speed Triple RS					
Key					
●	Standard (Factory Default Setting)				
○	Selectable Option				
∅	Option Not Available				

Bike Set Up Menu

The Bike Set Up menu allows configuration of the different features of the motorcycle.

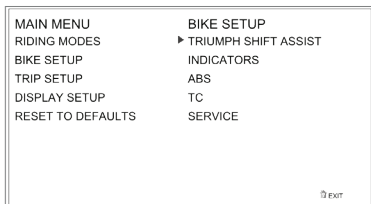

To access the Bike Set Up menu:

- Press the HOME button to display the Main menu.
- Push the joystick down and then press the joystick centre to select BIKE SET UP.

The options available are:

- Triumph Shift Assist (if fitted)
- Direction Indicators
- Anti-Lock Braking System (ABS)
- Traction Control (TC)
- Service.

Bike Set Up - Triumph Shift Assist (if fitted)

Triumph Shift Assist adjusts the engine torque to allow gears to engage, without closure of the throttle twist grip or operation of the clutch. This feature works for both up shifts and down shifts of gear.

For more information on Triumph Shift Assist functionality, see page 81.

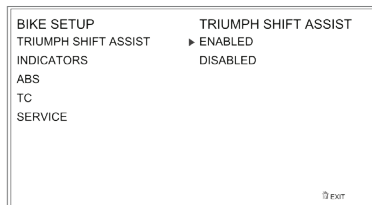

To enable/disable Triumph Shift Assist:

- From the Bike Set Up menu, push the joystick down to select TRIUMPH SHIFT ASSIST and press the joystick to confirm.
- Push the joystick down/up to scroll between ENABLED and DISABLED.
- Press the joystick centre to confirm the required selection.
- The display will then return to the BIKE SET UP menu.

Bike Set Up - Direction Indicators

The direction indicators can be set to Auto Basic, Auto Advanced or Manual mode.

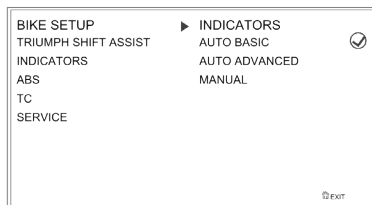

General Information

Selecting a Direction Indicators Mode

To select the required direction indicators mode:

- From the Bike Set Up menu, push the joystick down to select INDICATORS and press the joystick centre to confirm.
- Push the joystick down/up to scroll between AUTO BASIC, AUTO ADVANCED and MANUAL.
 - **Auto Basic** - The self-cancelling function is on. The direction indicators will activate for eight seconds and an additional 65 metres.
 - **Auto Advanced** - The self-cancelling function is on. A quick short press activates the direction indicators for three flashes. A longer press activates the direction indicators for eight seconds and an additional 65 metres.
 - **Manual** - The self-cancelling function is off. The direction indicators must be manually cancelled using the direction indicator switch.
- Press the joystick centre to confirm the required selection.
- The display will then return to the Bike Set Up menu.

Bike Set Up - ABS

It is possible to temporarily disable the ABS. The ABS cannot be permanently disabled, it will be automatically enabled when the ignition is turned off and then on again, or if the default riding mode is activated by a long press of the MODE button.

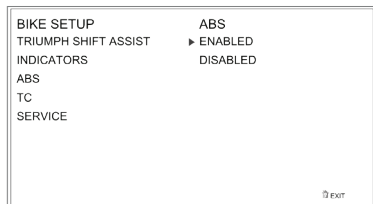

To select the required option:

- From the Bike Set Up menu, push the joystick down to select ABS and press the joystick centre to confirm.
- Push the joystick down/up to scroll between ENABLED and DISABLED.
- Press the joystick centre to confirm the required selection.
- The display will then return to the Bike Set Up menu.

Bike Set Up - Traction Control (TC)

It is possible to temporarily disable the traction control system. The traction control cannot be permanently disabled, it will be automatically enabled when the ignition is turned off and then on again, or if the default riding mode is activated by a long press of the MODE button.

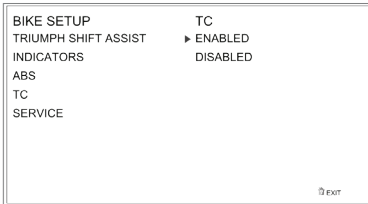

To select the required option:

- From the Bike Set Up menu, push the joystick down to select TC and press the joystick centre to confirm.
- Push the joystick down/up to scroll between ENABLED and DISABLED.
- Press the joystick centre to select the required option.

The display will then return to the BIKE SET UP display.

Bike Set Up - Service

The service interval is set to a distance and/or time period.

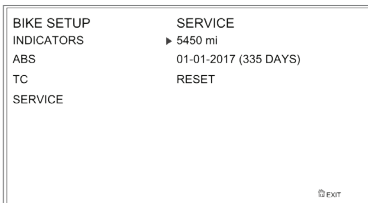

To review the service interval:

- From the Bike Set Up menu, push the joystick down to select SERVICE and press the joystick centre to confirm.
- Press the joystick centre to display the SERVICE information.
- Selecting RESET allows you to reset the standard time and distance, and also any custom times and distances up to the standard interval time.
- The display will then return to the Bike Set Up menu.

Trip Setup

The Trip Set Up menu allows configuration of the trip meters. Each trip meter can be configured to be reset either manually or automatically. The setup procedure is the same for both trip meters.

To access the Trip Set Up menu:

- Press the HOME button to display the Main menu.
- Push the joystick down and then press the joystick centre to select TRIP SET UP.

The options available are:

- TRIP 1 RESET
- TRIP 2 RESET
- TRIP 2 DISPLAY

General Information

Trip Setup - Manual Reset

Manual reset of the trip meters will only reset the selected trip meter when the rider chooses to do so.

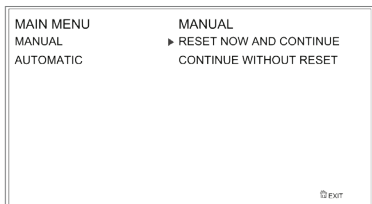

To set the trip meter to reset manually:

- Push the HOME button to display the MAIN MENU.
- Push the joystick down and then press the joystick centre to select TRIP SETUP.
- Push the joystick down and then press the joystick centre to select TRIP 1 RESET or TRIP 2 RESET.
- Push the joystick centre to select MANUAL.

There are two options:

- RESET NOW AND CONTINUE - Resets all trip meter data in the relevant trip meter, and the trip meter will only reset when manually done so by the rider.
 - CONTINUE WITHOUT RESET - The trip meter will not be reset. The trip meter will only reset when manually done so by the rider.
- Press the joystick centre to confirm the selection and return to the previous menu.

Trip Setup - Automatic Reset

Automatic reset will reset each trip meter after the ignition has been switched off for a set time.

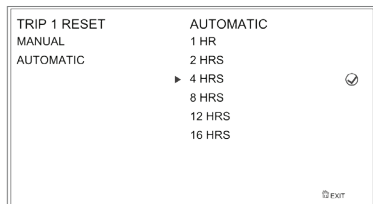

To set the trip meters to reset automatically:

- Push the HOME button to display the MAIN MENU.
- Push the joystick down and then press the joystick centre to select TRIP SETUP.
- Push the joystick down/up and then press the joystick centre to select TRIP 1 RESET or TRIP 2 RESET.
- Push the joystick down/up and select AUTOMATIC and then press the joystick centre.
- Push the joystick down/up to select the timer setting and press the joystick centre to confirm the required time limit. The required time limit is then stored in the trip memory.

When the ignition is turned off, the trip meter is set to zero when the time period has elapsed.

The following table shows two examples of the automatic trip reset functionality.

Ignition Turned Off	Selected Time Delay	Trip Meter Resets to Zero
10:30 hrs	4 HRS	14:30 hrs
18:00 hrs	16 HRS	10:00 hrs (next day)

Trip 2 Enable/Disable

Trip 2 meter can be enabled or disabled. If Trip 2 is disabled it will no longer be shown in the information tray.

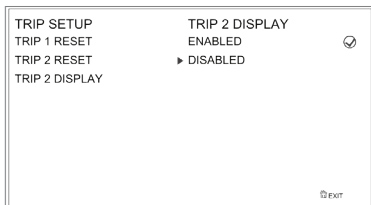

To enable or disable the Trip 2 meter:

- Push the MODE button to display the MAIN MENU.
- Push the joystick down to select TRIP SET UP.
- Push the joystick centre to display the TRIP SET UP menu.
- Push the joystick down/up to scroll to the TRIP 2 DISPLAY and press the joystick centre.
- Push the joystick down/up to scroll between ENABLED and DISABLED and press the joystick centre.

Display Set Up Menu

The Display Set Up menu allows configuration of the different display screen options.

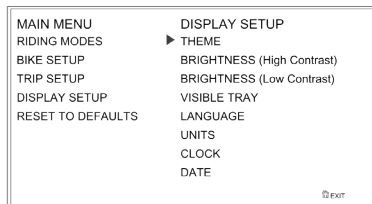

To access the Display Set Up menu:

- Press the HOME button to display the Main menu.
- Push the joystick down and then press the joystick centre to select DISPLAY SET UP.

The following options are available:

- Styles and Themes
- Brightness
- Visible Tray
- Language
- Set Units
- Set Clock
- Set Date.

General Information

Display Set Up - Themes and Styles

Note:

- Themes are only available on certain models.



Theme and Style Menu Example

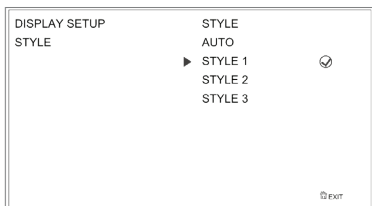

Style Menu Example

To select a style or theme:

- From the Display Set Up menu, push the joystick down to select the THEME (if fitted) and STYLES menu.
 - Speed Triple RS
Push the joystick down/up to scroll between the themes.
Press the joystick centre to confirm the selected theme.
Push the joystick down/up to scroll between the styles available with the selected theme.
Press the joystick centre to confirm the selected style.
 - Speed Triple S

Push the joystick down/up to scroll between the styles.

Press the joystick centre to confirm the selected style.

- The new theme or style will be saved. Press the HOME button to exit.

Note:

- Selecting AUTO will prevent a style tray from being displayed. The style is changed with riding modes.

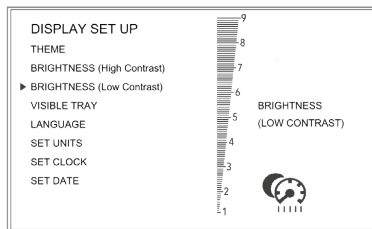

Display Set Up - Brightness

The brightness feature allows the screen's brightness contrast to be changed for day time and night time riding.



BRIGHTNESS (LOW CONTRAST) Shown

There are two brightness options to choose:

- High contrast (day time mode) 
- Low contrast (night time mode) 

To change the brightness level:

- From the Display Set Up menu, push the joystick down to select BRIGHTNESS and press the joystick centre to confirm.
- Push the joystick down to select BRIGHTNESS (High Contrast) or BRIGHTNESS (Low Contrast) menu.
- Press the joystick centre to select the required menu.
- Push the joystick down/up to adjust the brightness.
- Press the joystick centre to confirm the required level of brightness.
- Press the HOME button to return to the main display.

Note:

- **In bright sunlight, low brightness settings will be overridden to make sure that the instruments can be viewed at all times.**

Display Set Up - Visible Tray

The Visible Tray feature allows the selection of required information tray items to be shown in the information tray.

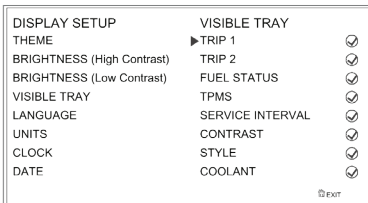

To select the Visible Tray menu:

- From the Display Set Up menu, push the joystick down to select VISIBLE TRAY and press the joystick centre to confirm.
- Push the joystick down/up until the required information tray item is selected.
- Press the joystick centre to select/deselect the information tray item.

An information tray item with a tick next to it will be shown in the tray. An information tray item without a tick next to it will not be shown in the tray.

Display Set Up - Language

There are several different languages that can be selected to be shown in the display screen.



To select a different language:

- From the Display Set Up menu, push the joystick down to select LANGUAGE and press the joystick centre to confirm.
- Push the joystick down/up until the required language is selected.
- Press the joystick centre to select/deselect the required language.

General Information

Display Set Up - Set Units

There are different units of measurement options that can be shown in the display screen.

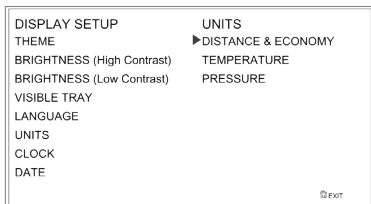

To select the units of measurement required:

- From the Display Set Up menu, push the joystick down to select SET UNITS and press the joystick centre to confirm.
- Push the joystick down/up to select the required unit; DISTANCE and ECONOMY, TEMPERATURE or PRESSURE.
- Push the joystick down/up to select the required unit of measurement from the following options:
 - **DISTANCE and ECONOMY:**
 - MILES and MPG (UK)
 - MILES and MPG (US)
 - KM and L/100KM
 - KM and KM/L
 - **TEMPERATURE:**
 - °C
 - °F
 - **PRESSURE:**
 - PSI
 - BAR
 - KPa
- Press the joystick centre to confirm.

Display Set Up - Set Clock

This function allows the adjustment of the clock.

To set the clock:

- From the Display Set Up menu, push the joystick down to select SET CLOCK and press the joystick centre to confirm.
- Push the joystick down/up to select between either 12 HR or 24 HR clock and press the joystick centre to confirm selection. The clock will display in either 12 or 24 hour format. Once the clock format is set the display will return to the SET CLOCK menu.

To set the time, push the joystick down/up to select HOUR or MINUTE.

To adjust the hour setting:

- Select HOUR on the display and press the joystick centre, a tick will appear next to HOUR and the hour display will flash as shown below.
- Push the joystick down/up to set the hour and press the joystick centre to confirm.

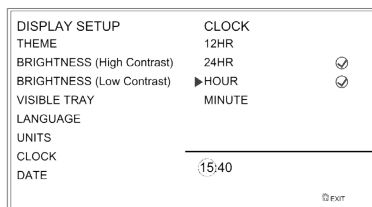

To adjust the minute setting:

- Select MINUTE on the display and press the joystick centre, a tick will appear next to MINUTE and the minute display will flash as shown below.
- Push the joystick down/up to set the minute and press the joystick centre to confirm.

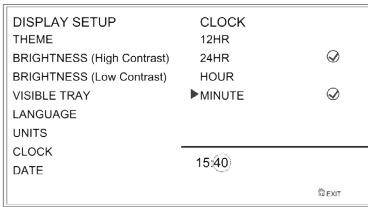

Display Set Up - Set Date

This function allows the adjustment of the date and date format.

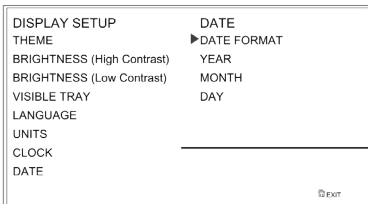

To set the date format:

- From the Display Set Up menu, push the joystick down to select SET DATE and press the joystick centre to confirm.
- Press the joystick centre to display DATE FORMAT.
- Push the joystick down/up to select either of the DD-MM-YYYY, MM-DD-YYYY or YYYY-MM-DD formats and press the joystick centre to confirm selection. Once the date format is set the display will return to the SET DATE menu.

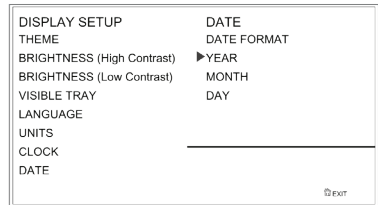

To set the date, push the joystick down/up to select the DAY, MONTH and YEAR.

- Select YEAR and then press the joystick centre, a tick will appear next to the YEAR and the YEAR display will flash.
- Push the joystick down/up to set the current year and then press the joystick centre to confirm.
- To set the MONTH and DAY repeat the procedure used to set the year. Once the date is set the display will return to the SET DATE menu.

General Information

Reset to Defaults

This function allows the main menu display items to be reset to the default setting.

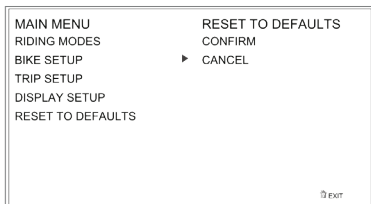

To reset the Main menu display items:

- From the Main menu, push the joystick down and select **RESET TO DEFAULTS**.
- Press the joystick centre to confirm.
- Pushing the joystick down/up, select **CONFIRM** or **CANCEL** from the Reset to Defaults menu, and press the joystick centre to confirm.
- **Confirm** - The following main menu settings and data will be reset to the factory default values - Riding Modes, Indicator Set Up, Trip Computers, Visible Trays, Language, ABS, Traction Control, Style, and Display Brightness.
- **Cancel** - The main menu settings and data will remain unchanged and the display will return to the previous level.

Instrument Panel Position Adjustment

Warning

Operation of the motorcycle with an incorrectly adjusted instrument panel is dangerous.

An incorrectly adjusted instrument panel will result in loss of instrument vision when riding and may cause a distraction leading to loss of control of the motorcycle and an accident.

Always adjust the instrument panel to provide sufficient vision of the instruments before riding the motorcycle.

Warning

Never attempt to clean or adjust the instrument panel while riding the motorcycle. Removal of the rider's hands from the handlebars while riding the motorcycle will diminish the ability of the rider to maintain control of the motorcycle.

Attempting to clean or adjust the instrument panel while riding the motorcycle may result in loss of control of the motorcycle and an accident.

Only attempt to clean or adjust the instrument panel while stationary.

⚠ Caution

Do not press directly onto the instrument panel display screen.

Only adjust the position of the instrument panel using the adjustment handle.

Pressing directly on the instrument panel display screen may damage the instrument panel.

The instrument panel can be adjusted to allow for improved visibility of the display screen.

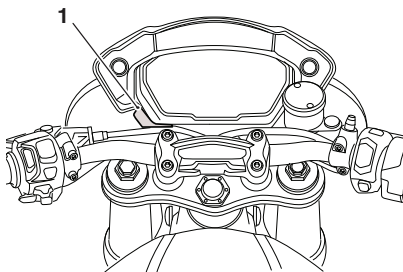

1. Adjustment handle

To adjust the instrument panel:
Position the instrument panel to allow an unobstructed view of the display screen using the adjustment handle.

Note:

- **Moderate force using the thumb and finger is required to adjust the position of the instrument panel.**

Hand Controls

Keyless Ignition (if fitted)

The keyless ignition system allows the motorcycle to be started without the use of a mechanical key.

There are three keys supplied with the motorcycle. One smart key and two standard keys.



Smart Key

Note:

- **An additional smart key can be purchased from your Triumph dealer.**
- **However, only three keys can be programmed to the motorcycle. This can be a combination of smart keys and standard keys.**

Smart Key Operation

Press the button on the smart key to turn the key on. The button light shows green briefly to indicate that the smart key is on.

General Information

A short press on the smart key button shows the status of the smart key; red is OFF and green is ON. A long press of the button will change the status to OFF or ON after briefly showing the original status colour first.

The smart key must be within close proximity (one metre/three feet) of the system sensor, which is located in the centre of the motorcycle under the rider's seat. If the smart key is out of range of the system sensor then it will be unresponsive and the keyless ignition cannot be activated.

If the smart key battery is flat, then use the smart key in the standard key operation method.

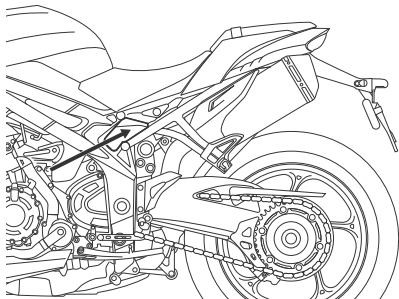

System Sensor Access

For more information on starting the engine with keyless ignition, see page **78**.

Standard Key Operation

Warning

If the engine has recently been running, the exhaust components may be hot to the touch. Contact with the hot components may cause damage to exposed skin. To avoid skin damage, always allow the hot parts to cool before touching the exhaust system.

To turn the motorcycle on with the standard key, position the standard key in to the area of the rear and main frame as shown in the figure above.

Hold the standard key against the centre of the underseat tray (as viewed from above), directly above the RSU reservoir.

The standard key must be held against the system sensor while pressing the Engine Start/Stop switch in either the QUICK START or Power ON/OFF position (see page **53**).

Caution

All keys supplied with the motorcycle are specific to the individual motorcycle. They cannot be used on another motorcycle.

If all keys are lost, misplaced or damaged, then the chassis control unit on the motorcycle will need to be replaced.

To avoid unnecessary cost and time, make sure that all spare keys are kept in a secure location.

⚠ Caution

If there is a fault with the smart key or the smart key battery is flat then take the smart key to the nearest Triumph dealer to rectify.

Master Ignition Switch (if fitted)

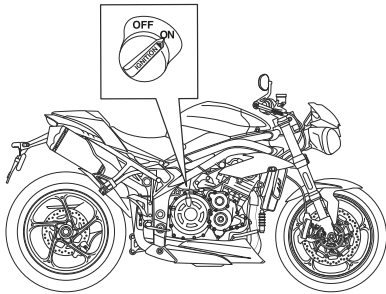

Master Ignition Switch

The master ignition switch is only fitted to motorcycles in the United States and Canada. The master ignition switch is located on the right hand side of the motorcycle.

To operate the motorcycle with the keyless ignition, the master ignition switch must be in the ON position.

If the master ignition switch is in the OFF position then the keyless ignition cannot be used and the motorcycle can not be started.

Ignition Key

Speed Triple S Only

⚠ Warning

Additional keys, key rings/chains or items attached to the ignition key may interfere with the steering, leading to loss of motorcycle control and an accident.

Remove all additional keys, key rings/chains and items from the ignition key before riding the motorcycle.

⚠ Caution

Additional keys, key rings/chains or items attached to the ignition key may cause damage to the motorcycle's painted or polished components.

Remove all additional keys, key rings/chains and items from the ignition key before riding the motorcycle.

General Information

! Caution

Do not store the spare key with the motorcycle as this will reduce all aspects of security.

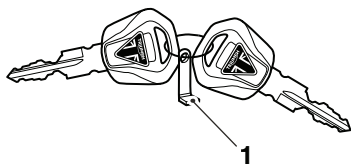

cixj

1. Key number tag

In addition to operating the steering lock/ignition switch, the ignition key is required to operate the seat lock and fuel tank cap.

When the motorcycle is delivered from the factory, two keys are supplied together with a small tag bearing the key number. Make a note of the key number and store the spare key and key number tag in a safe place away from the motorcycle.

A transponder is fitted within the key to turn off the engine immobiliser. To ensure the immobiliser functions correctly, always have only one of the ignition keys near the ignition switch. Having two ignition keys near the switch may interrupt the enable signal between the transponder and the engine immobiliser. In this situation the engine immobiliser will remain on until one of the ignition keys is removed.

Always get replacement keys from your authorised Triumph dealer. Replacement keys must be 'paired' with the motorcycle's immobiliser by your authorised Triumph dealer.

Ignition Switch/Steering Lock

Speed Triple S Only

! Warning

For reasons of security and safety, always move the ignition switch to the OFF position and remove the key when leaving the motorcycle unattended.

Any unauthorised use of the motorcycle may cause injury to the rider, other road users and pedestrians and may also cause damage to the motorcycle.

! Warning

With the key in the LOCK or P position the steering will become locked.

Never turn the key to the LOCK or P positions while the motorcycle is moving as this will cause the steering to lock.

Locked steering will cause loss of motorcycle control and an accident.

This is a four position, key operated switch. The key can be removed from the switch only when it is in the OFF, LOCK or P (PARK) position.

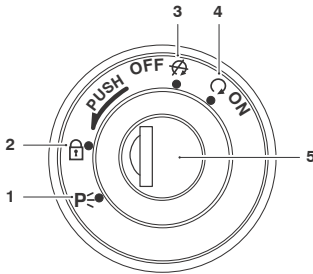

1. PARK position
2. LOCK position
3. OFF position
4. ON position
5. Ignition switch/Steering lock

To lock the steering:

- Turn the steering fully to the left.
- Turn the key to the OFF position.
- Push and fully release the key.
- Rotate it to the LOCK position.

To park:

- Turn the key from the LOCK position to the P position.
- The steering will remain locked.

Engine Immobiliser

The ignition barrel housing acts as the antenna for the engine immobiliser.

When the ignition switch is turned to the OFF position and the ignition key removed, the engine immobiliser is on. The engine immobiliser is turned off when the ignition key is in the ignition switch and it is turned to the ON position.

Right Handlebar Switches

Speed Triple RS

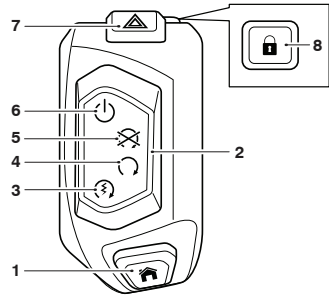

1. HOME button
2. Engine start/stop switch
3. QUICK START position
4. RUN position
5. STOP position
6. Power ON/OFF position
7. Hazard warning lights switch
8. Steering lock button

The following sections describe the handlebar buttons and switches functions.

HOME Button

The HOME button is used to access the main menu on the instrument display.

Press and release the HOME button to select between the main menu and instrument display.

General Information

QUICK START Position

The QUICK START position operates the electric starter allowing for a quicker engine start.

From the ignition off, press and hold the engine start/stop switch in the QUICK-START position with all the correct conditions met, to start the motorcycle.

For more information, see page 78.

RUN Position

The engine start/stop switch must be in the RUN position for the motorcycle to operate.

STOP Position

The STOP position stops the engine.

Note:

- **Although the engine stop position stops the engine, it does not turn off all the electrical circuits and may cause difficulty in restarting the engine due to a discharged battery.**

Power ON/OFF Position

The Power ON/OFF position switches the electrical circuits and the instrument display between on or off. This allows access to the instrument display without starting the engine.

Caution

Do not leave the switch in the Power ON position for a long period of time as this may cause damage to electrical components and will discharge the battery.

Hazard Warning Lights Button

To turn the hazard warning lights on or off, press and release the hazard warning light button.

The ignition must be switched on for the hazard warnings lights to be activated, but the hazard lights will remain active if the ignition is switched off until the hazard warning light button is pressed again.

Steering Lock Button

To lock the motorcycle, turn the handlebar fully to the left and press the steering lock button.

Warning

For reasons of security and safety, always make sure the steering lock is on when leaving the motorcycle unattended.

Any unauthorised use of the motorcycle may cause injury to the rider, other road users and pedestrians and may also cause damage to the motorcycle.

Right Handlebar Switches

Speed Triple S

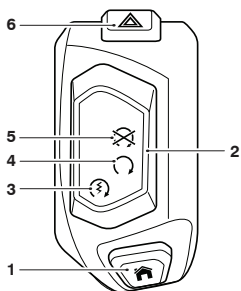

1. HOME button
2. Engine start/stop switch
3. START position
4. RUN position
5. STOP position
6. Hazard warning lights switch

The following sections describe the handlebar buttons and switches functions.

HOME Button

The HOME button is used to access the main menu on the instrument display.

Press and release the HOME button to select between the main menu and instrument display.

Engine Stop Switch

In addition to the ignition switch being turned to the ON position, the engine stop switch must be in the RUN position for the motorcycle to operate.

The engine stop switch is for emergency use. If an emergency arises which requires the engine to be stopped, move the engine stop switch to the STOP position.

Note:

- Although the engine stop switch stops the engine, it does not turn off all the electrical circuits and may cause difficulty in restarting the engine due to a discharged battery. Ordinarily, only the ignition switch should be used to stop the engine.

Caution

Do not leave the ignition switch in the ON position unless the engine is running as this may cause damage to electrical components and will discharge the battery.

Starter Button

The starter button operates the electric starter. For the starter to operate, the clutch lever must be pulled to the handlebar.

Note:

- Even if the clutch lever is pulled to the handlebar, the starter will not operate if the side stand is down and a gear is engaged.

Hazard Warning Lights Button

To turn the hazard warning lights on or off, press and release the hazard warning light button.

The ignition must be switched on for the hazard warnings lights to be activated, but the hazard lights will remain active if the ignition is switched off until the hazard warning light button is pressed again.

General Information

Left Handlebar Switches

All Models

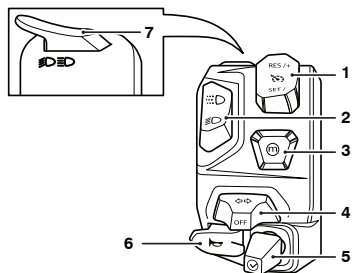

1. Cruise control adjust switch
2. Daytime Running Lights (DRL) switch (if fitted)
3. MODE button
4. Direction indicator switch
5. Joystick button
6. Horn button
7. High beam button

The following sections describe the handlebar buttons and switches functions.

Cruise Control Adjust Button

The cruise control adjust button is a two way switch with the top marked RES/+ and the bottom marked SET/-.

For more information on cruise control operation, see page 61.

Daytime Running Lights (DRL) Switch (if fitted)



When the ignition is switched ON and the daytime running lights switch is set to DRL mode, the daytime running lights warning light will illuminate.

The daytime running lights and low beam headlights are operated manually using the DRL switch. Push the switch forward to the top for DRL mode, and push the switch rearward to the bottom for low beam headlight mode.

Warning

Do not ride for longer than necessary in poor ambient light conditions with the Daytime Running Lights (DRL) in use.

Riding with the daytime running lights when dark, in tunnels or where poor ambient light is apparent may reduce the riders vision or dazzle other road users.

Dazzling other road users or reduced vision in low ambient light levels may result in loss of motorcycle control and an accident.

Note:

- During daylight hours the daytime running lights improve the motorcycles visibility to other road users.
- Low beam headlights must be used in any other conditions unless the road conditions allow for high beam headlights to be used.

MODE Button

When the MODE button is pressed and released it will activate the Riding Mode Selection Menu in the display screen. Further presses of the MODE button will scroll through the available riding modes, see Riding Mode Selection on page 29.

Press and hold the MODE button to activate the ROAD mode, and enable ABS and traction control, if disabled.

For more information on riding mode selection and configuration, see page 38.

Direction Indicator Switch

When the indicator switch is pushed to the left or right and released, the corresponding direction indicators will flash on and off. To turn off the indicators, push and release the switch in the central position.

Models Equipped with Automatic Self-Cancelling Indicators

A short press and release of the indicator switch to the left or right will cause the corresponding direction indicators to flash on and off three times, then turn off.

A longer press and release of the indicator switch to the left or right will cause the corresponding direction indicators to flash on and off.

The indicators are automatically turned off after eight seconds and after riding a further 65 metres.

To disable the indicator self-cancel system refer to the Bike Setup section on page 39.

The indicators can be cancelled manually. To manually turn off the indicators, press and release the indicator switch in the central position.

Joystick Button

The Joystick is used to operate the following functions of the instruments:

- Up - scroll the menu from the bottom to the top
- Down - scroll the menu from the top to the bottom
- Left - scroll the menu to the left
- Right - scroll the menu to the right
- Centre - press to confirm selection.

Horn Button

When the horn button is pushed, with the ignition switch turned on, the horn will sound.

High Beam Button

The high beam button has a different function depending on whether Daytime Running Lights (DRL) are fitted or not. When the high beam is turned on, the high beam indicator light will illuminate in the display.

Models with Daytime Running Lights (DRL)

If the DRL switch is in the Daytime Running Lights (DRL) position, then press and hold the high beam button to turn the high beam on. It will remain on as long as the button is held in and will turn off as soon as the button is released.

General Information

If the DRL switch is in the dip beam position, press the high beam button to switch the high beam on. Each press of the button will swap between dip and high beam.

Note:

- **A lighting on/off switch is not fitted to this model. The rear light and licence plate light all function automatically when the ignition is turned on.**
- **The headlight will function when the ignition is turned on and the engine is running.**

Models without Daytime Running Lights (DRL)

Press the high beam button to switch the high beam on. Each press of the button will swap between dip and high beam.

Note:

- **A lighting on/off switch is not fitted to this model. The position light, rear light and licence plate light all function automatically when the ignition is turned on.**
- **The headlight will function when the ignition is turned on and the engine is running.**

Brake and Clutch Lever Adjusters



Do not attempt to adjust the levers with the motorcycle in motion as this may lead to loss of motorcycle control and an accident.

After adjusting the levers, operate the motorcycle in an area free from traffic to gain familiarity with the new lever setting.

Do not loan your motorcycle to anyone as they may change the lever setting from the one you are familiar with causing loss of control or an accident.

An adjuster is fitted to both the front brake and clutch levers. The adjusters allow the distance from the handlebar to the levers to be changed to suit the span of the operator's hands.

Front Brake Lever - Speed Triple RS

Two adjusters are fitted to the brake lever; a span adjuster and a ratio adjuster.

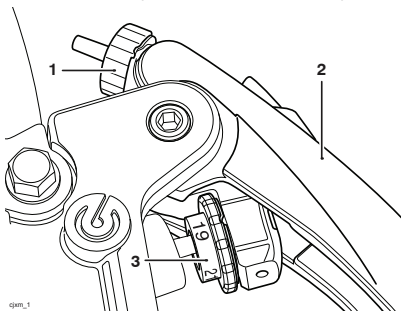

1. **Span adjuster wheel**
2. **Brake lever**
3. **Ratio adjuster**

Span Adjuster

The span adjuster wheel allows the distance from the handlebar to the brake lever to be changed to suit the span of the operator's hands.

To adjust the front brake lever, rotate the span adjuster wheel anticlockwise to decrease the distance to the handlebar or clockwise to increase the distance from the handlebar.

The distance from the handlebar grip to the released brake lever is shortest when the span adjuster wheel is adjusted fully anticlockwise.

Ratio Adjuster

The ratio adjuster moves the brake master cylinder push rod to the left or right in 1 mm increments from 19 mm to 21 mm. 19 mm provides the rider with a longer/softer braking action whilst 21 mm provides a shorter/firmer lever action.

To adjust the front brake lever, turn the ratio adjuster to the rider's preferred position. The rotary wheel will rotate and click into position.

The ratio adjuster has three lever positions:

- 19 (19 mm) for a softer brake feel with a longer lever travel
- 20 (20 mm) for a firmer brake feel and a medium lever travel
- 21 (21 mm) for a firm brake feel and a shorter lever travel.

Note:

- **An audible click can be heard when the ratio wheel is locked into position.**
- **Four marks are visible on the wheel, 19 - 20 - 21 - 20.**
- **The ratio wheel can be turned both clockwise and anticlockwise to set the desired preference.**

Front Brake Lever - Speed Triple S

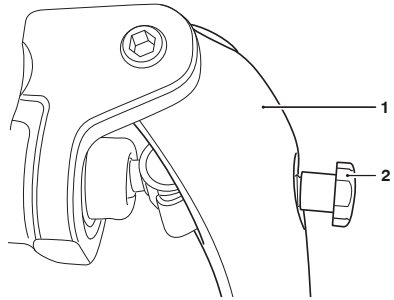

1. **Brake lever**
2. **Adjusting screw**

To adjust the brake lever:

- Push the brake lever forward.
- Turn the adjusting screw in to increase the distance or out to shorten the distance from the handlebar.

General Information

Clutch Lever

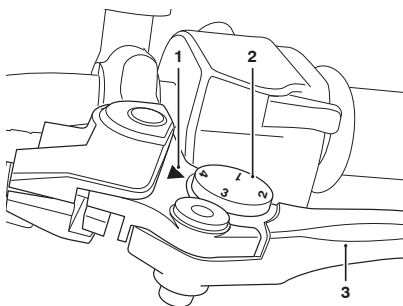

1. **Triangular mark**
2. **Adjuster wheel**
3. **Clutch lever**

To adjust the clutch lever:

- Push the lever forward and turn the adjuster wheel to align one of the numbered positions with the triangular mark on the lever holder.
- The distance from the handlebar grip to the released lever is shortest when set to number four and longest when set to number one.

Throttle Control



Warning

Always be alert for changes in the 'feel' of the throttle control and have the throttle system checked by an authorised Triumph dealer if any changes are detected. Changes can be due to wear in the mechanism, which could lead to a sticking throttle control.

A sticking or stuck throttle control will lead to loss of motorcycle control and an accident.

The motorcycle has an electronic throttle twist grip to open and close the throttles. There are no direct-acting cables in the system and no adjustments can be made.

Check that the throttle opens smoothly, without undue force and that it closes without sticking.

Check that there is 1 - 2 mm of throttle grip free play when lightly turning the throttle grip back and forth.

If there are any changes or an incorrect amount of free play, then have your authorised Triumph dealer check the throttle system.

If there is a malfunction with the throttle control the Malfunction Indicator Light (MIL) becomes illuminated and one of the following engine conditions may occur:

- MIL illuminated, restricted engine RPM and throttle movement
- MIL illuminated, limp-home mode with the engine at a fast idle condition only
- MIL illuminated, engine will not start.

For all of the conditions mentioned contact an authorised Triumph dealer as soon as possible to have the fault checked and rectified.

Cruise Control

Warning

Cruise control must only be used where you can drive safely at a steady speed.

Cruise control should not be used when riding in heavy traffic, on roads with sharp/blind bends or when they are slippery.

Using cruise control in heavy traffic, on roads with sharp/blind bends or when they are slippery, may result in loss of motorcycle control and an accident.

Warning

This Triumph motorcycle should be operated within the legal speed limits for the particular road travelled.

Operating a motorcycle at high speeds can be potentially dangerous since the time available to react to given traffic situations is greatly reduced as speed increases.

Always reduce speed in consideration of weather and traffic conditions.

Warning

Only operate this Triumph motorcycle at high speed in closed-course, on-road competition or on closed-course racetracks. High speed operation should only then be attempted by riders who have been instructed in the techniques necessary for high speed riding and are familiar with the motorcycle's behaviour in all conditions.

High speed operation in any other circumstances is dangerous and will lead to loss of motorcycle control and an accident.

Note:

- **Cruise control may not function if there is a malfunction with the ABS system and the ABS warning light is illuminated.**
- **Cruise control will continue to function if a riding mode is selected with ABS set to Off-Road or Off.**
- **Cruise control will continue to function if ABS has been disabled.**

General Information

The cruise control buttons are located on the left hand switch housing and can be operated with minimum movement by the rider.

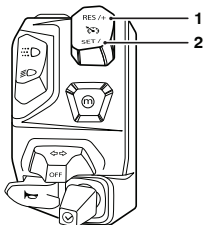

1. Cruise control RES/+ button
2. Cruise control SET/- button

Cruise control can be switched on or off at any time but it cannot be activated until all the conditions described on page 62 have been met.

Activating Cruise Control

To turn on the cruise control system, press the SET/- button. The cruise control symbol will be shown in the display screen. The cruise control set speed will be shown as '--' indicating that a speed has not yet been set.

To activate cruise control, the following conditions have to be met:

- The motorcycle must be travelling at a speed between 19 to 100 mph (30 to 160 km/h).
- The motorcycle must be in 3rd gear or higher.
- Once these conditions have been met, press the SET/- button to activate cruise control. The cruise control symbol will be shown in a green light in the TFT display to indicate that cruise control is now active.

The word SET will be shown next to the cruise control symbol. The cruise control set speed will be shown and the cruise control light will illuminate in the tachometer indicating that cruise control is active.

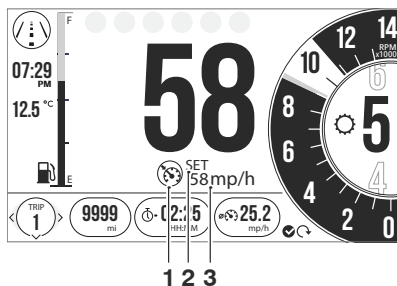

1. Cruise control symbol
2. Cruise control set indicator
3. Cruise control set speed

The cruise control system will maintain the set speed until:

- The set speed is adjusted as described on page 63.
- Cruise control is deactivated as described on page 63.

Adjusting the Set Speed While in Cruise Control

To adjust the set speed while in cruise control, press and release the:

- RES/+ button to increase the speed
- SET/- button to decrease the speed.

Each press of the buttons will adjust the speed by 1 mph or 1 km/h. If the buttons are held, the speed continuously increases or decreases in single digit increments.

Stop pressing the adjust button when the desired speed is shown in the display.

Note:

- **The cruise control set speed display will flash until the new set speed has been achieved.**
- **If riding up a steep incline and cruise control is unable to maintain the set speed, the cruise control set speed display will flash until the motorcycle has regained the set speed.**

An alternative way to increase the speed in cruise control is to accelerate to the desired speed using the throttle grip and then press the SET/- button.

Deactivating Cruise Control

The cruise control can be deactivated by one of the following methods:

- Roll the throttle twist grip fully forward.
- Pull the clutch lever.
- Operate the front or rear brake.
- Increase speed by using the throttle for more than 60 seconds.

Press and hold the -/SET button.

Upon deactivation, the cruise control light will go out in the tachometer but the SET indicator and set speed will still be shown in the display screen, indicating that the cruise control set speed has been stored.

The cruise control set speed can be resumed as described on page 63, provided the cruise control has not been deactivated by turning the ignition switch to the OFF position.

Resuming the Cruise Control Set Speed

Warning

When resuming cruise control, always make sure that the traffic conditions are suitable for the set speed.

Using cruise control in heavy traffic, on roads with sharp/blind bends or when they are slippery, may result in loss of motorcycle control and an accident.

General Information

Cruise control will be deactivated if one of the following actions has been taken:

- Roll the throttle twist grip fully forward.
- Pull the clutch lever.
- Operate the front or rear brake.
- Increase speed by using the throttle grip for more than 60 seconds.

The cruise control set speed can be resumed by pressing and releasing the RES/+ button provided a set speed has been stored.

The motorcycle must be travelling at a speed between 19 to 100 mph (30 to 160 km/h) and be in 3rd gear or higher.

A stored set speed is indicated by the word SET next to the cruise control symbol in the display screen.

The stored set speed will remain in the cruise control memory until the ignition switch has been turned to the OFF position.

Note:

- **The cruise control set speed display will flash until the resumed set speed has been achieved.**

Tyre Pressure Monitoring System (TPMS) (if fitted)



Warning

The daily check of tyre pressures must not be excluded because of the fitment of the TPMS. Check the tyre pressure when the tyres are cold using an accurate tyre pressure gauge (see page 127).

Use of the TPMS system to set inflation pressures may lead to incorrect tyre pressures leading to loss of motorcycle control and an accident.

Note:

- **The Tyre Pressure Monitoring System (TPMS) is an accessory option only available on models fitted with cast alloy wheels. It must be fitted by your authorised Triumph dealer.**

Tyre pressure sensors are fitted to the front and rear wheels. These sensors measure the air pressure inside the tyre and transmit pressure data to the instruments. These sensors will not transmit the data until the motorcycle is travelling at a speed greater than 12 mph (20 km). Two dashes will be shown in the display screen until the tyre pressure signal is received. The sensors in each wheel work independent of each other. Therefore the sensors can automatically switch on and update at different times.

An adhesive label will be fitted to the wheel rim to indicate the position of the tyre pressure sensor which is near the valve.

The TPMS display screen on the instruments will only be activated when the system has been fitted.

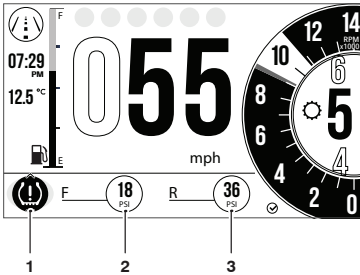

1. TPMS warning light
2. Front tyre pressure indicator
3. Rear tyre pressure indicator

Tyre Pressures

! Warning

The tyre pressure monitoring system is not to be used as a tyre pressure gauge when adjusting the tyre pressures. For correct tyre pressures, always check the tyre pressures when the tyres are cold and using an accurate tyre pressure gauge.

Use of the TPMS system to set inflation pressures may lead to incorrect tyre pressures leading to loss of motorcycle control and an accident.

! Caution

Do not use anti puncture fluid or any other item likely to obstruct air flow to the TPMS sensor's orifices. Any blockage to the air pressure orifice of the TPMS sensor during operation will cause the sensor to become blocked, causing irreparable damage to the TPMS sensor assembly.

Damage caused by the use of anti puncture fluid or incorrect maintenance is not considered a manufacturing defect and will not be covered under warranty.

Always have your tyres fitted by your authorised Triumph dealer and inform them that tyre pressure sensors are fitted to the wheel.

The tyre pressures shown on your instrument panel indicate the actual tyre pressure at the time of selecting the display. This may differ from the inflation pressure set when the tyres are cold because tyres become warmer during riding, causing the air in the tyre to expand and the pressure to increase. The cold inflation pressures specified by Triumph take account of this.

Owners must only adjust tyre pressures when the tyres are cold using an accurate tyre pressure gauge, and must not use the tyre pressure display on the instruments. For the recommended tyre pressures, see the Specification section.

General Information

Tyre Pressure Sensor Serial Number

The serial number for the tyre pressure sensor is printed on a label attached to the sensor. This number may be required by your authorised Triumph dealer for service or diagnostics.

When the tyre pressure monitoring system is being fitted to the motorcycle, make sure that your authorised Triumph dealer records the serial numbers of the front and rear tyre pressure sensors in the spaces provided below.

Front Tyre Pressure Sensor

Rear Tyre Pressure Sensor

Sensor Batteries

When the battery voltage in a pressure sensor is low, a message will be shown in the display screen and the TPMS symbol will indicate which wheel sensor has the low battery voltage. If the batteries are completely flat, only dashes will be shown in the display screen, the red TPMS warning light will be on and the TPMS symbol will flash continuously. Contact your authorised Triumph dealer to have the sensor replaced and the new serial number recorded in the spaces provided on page **66**.

With the ignition turned on, if the TPMS symbol is shown and the TPMS warning light remains on there is a fault with the TPMS system. Contact your authorised Triumph dealer to have the fault rectified.

Replacement Tyres

When replacing tyres, always have an authorised Triumph dealer fit your tyres and make sure they are aware that tyre pressure sensors are fitted to the wheels.

Fuel



Fuel Grade

Your Triumph engine is designed to use unleaded fuel and will give optimum performance if the correct grade of fuel is used. Always use unleaded fuel with a minimum octane rating of 91 RON.

In certain circumstances engine calibration may be required. Always refer to your authorised Triumph dealer.

Caution

The motorcycle can be permanently damaged if it is allowed to operate with the incorrect grade of fuel or incorrect engine calibration.

Always make sure the fuel used is of the correct grade and quality.

Damage caused by using the incorrect fuel or engine calibration is not considered a manufacturing defect and will not be covered under warranty.

Caution

The exhaust system for this motorcycle is fitted with a catalytic converter to help reduce exhaust emission levels.

Use of leaded fuel will damage the catalytic converter. In addition, the catalytic converter can be permanently damaged if the motorcycle is allowed to run out of fuel or if the fuel level is allowed to get very low.

Always make sure you have adequate fuel for your journey.

Note:

- **The use of leaded fuel is illegal in some countries, states or territories.**

General Information

Refuelling

Warning

To help reduce hazards associated with refuelling, always observe the following fuel safety instructions:

- Petrol (fuel) is highly flammable and can be explosive under certain conditions. When refuelling, turn the ignition switch to the OFF position.
- Do not smoke.
- Do not use a mobile telephone.
- Make sure the refuelling area is well ventilated and free from any source of flame or sparks. This includes any appliance with a pilot light.
- Never fill the tank until the fuel level rises into the filler neck. Heat from sunlight or other sources may cause the fuel to expand and overflow creating a fire hazard.
- After refuelling always check that the fuel filler cap is correctly closed.
- Because petrol (fuel) is highly flammable, any fuel leak or spillage, or any failure to observe the safety advice given above will lead to a fire hazard, which could cause damage to property, injury to persons or death.

Fuel Tank Cap

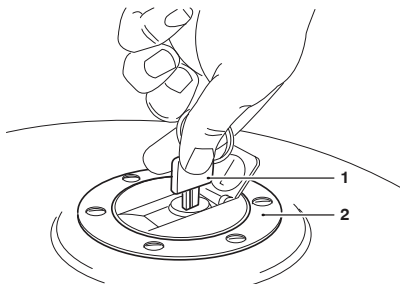

1. Key
2. Fuel tank cap

To open the fuel tank cap:

- Lift up the flap covering the lock itself.
- Insert the key into the lock and turn the key clockwise.

To close and lock the cap:

- Push the cap down into place with the key inserted, until the lock 'clicks' into place.
- Withdraw the key and close the key cover.

Caution

Closing the cap without the key inserted will damage the cap, tank and lock mechanism.

Filling the Fuel Tank

Warning

Overfilling the tank can lead to fuel spillage.

If fuel is spilled, thoroughly clean up the spillage immediately and dispose of the materials used safely.

Take care not to spill any fuel on the engine, exhaust pipes, tyres or any other part of the motorcycle.

Because fuel is highly flammable, any fuel leak or spillage, or any failure to observe the safety advice given above may lead to a fire hazard, which could cause damage to property and injury or death to persons.

Fuel spilled near to, or onto the tyres will reduce the tyres' ability to grip the road. This will result in a dangerous riding condition potentially causing loss of motorcycle control and an accident.

Caution

Avoid filling the tank in rainy or dusty conditions where airborne material can contaminate the fuel.

Contaminated fuel may cause damage to fuel system components.

Fill the fuel tank slowly to help prevent spillage. Do not fill the tank to a level above the bottom of the filler neck. This will make sure there is enough air space to allow for fuel expansion if the fuel inside the tank expands through absorption of heat from the engine or from direct sunlight.

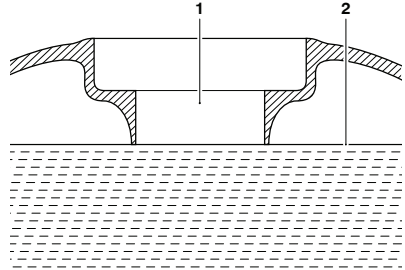

1. **Fuel filler neck**
2. **Maximum fuel level**

After refuelling always check that the fuel filler cap is correctly closed.

General Information

Seats

Note:

- The passenger seat must be removed to access the rider's seat for removal.

Seat Care

⚠ Caution

To prevent damage to the seat or seat cover, care must be taken not to drop the seat.

Do not lean the seat against the motorcycle or any surface which may damage the seat or seat cover. Instead, place the seat, with the seat cover facing upwards, on a clean, flat surface which is covered with a soft cloth.

Do not place any item on the seat which may cause damage or staining to the seat cover.

For seat cleaning information, see page **148**.

Seat Lock

The seat lock is located on the left hand side of the motorcycle, on the frame below the seat.

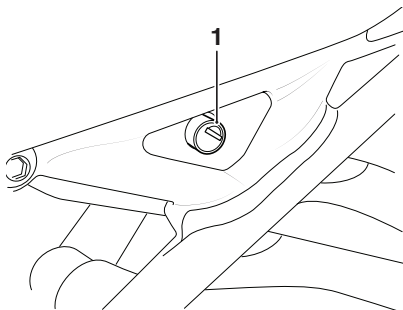

1. Seat lock

Passenger Seat Removal

To remove the passenger seat:

- Insert the ignition key into the seat lock and turn it anticlockwise while pressing down on the front part of the passenger seat. This will release the seat from its lock.
- Lift the front of the seat and slide forwards for complete removal from the motorcycle.

Passenger Seat Installation

Note:

- The rider's seat must be correctly installed before attempting to install the passenger seat.

To install the passenger seat:

- Position the rear of the passenger seat to the rear locator in the rear subframe.

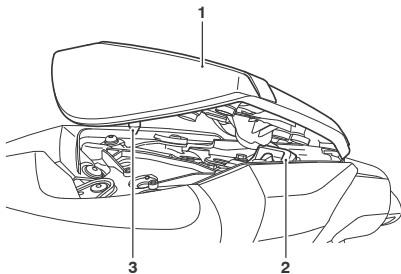

1. Passenger seat
2. Rear locator
3. Seat lock hook

- Locate the seat lock hook into the lock plate assembly and press down to engage it in the lock. An audible click can be heard when the seat is correctly engaged in the lock.

Warning

To prevent detachment of the seat during riding, after fitting always grasp the seat and pull firmly upwards.

If the seat is not correctly secured in the lock, it will detach from the lock.

A loose or detached seat could cause loss of motorcycle control and an accident.

Rider's Seat Removal

Note:

- The passenger seat must be removed before attempting to remove the rider's seat.

To detach the rider's seat:

- Remove the passenger seat as described on page 70.
- A tool is located at the rear of the passenger seat. Using the tool, remove the two fixings securing the rider's seat to the lock plate.

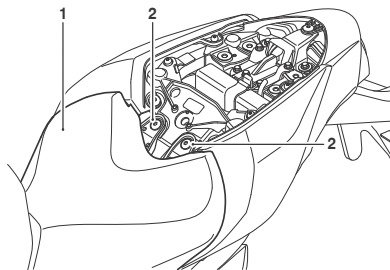

1. Rider's seat
2. Fixings

- Slide the seat rearwards and lift the rear of the seat.
- Disengage the locators from the frame, and the front bracket from below the fuel tank hinge.

General Information

Rider's Seat Installation

To install the rider's seat:

- Position the seat's front bracket under the fuel tank hinge and the rear location into position in the rear subframe.

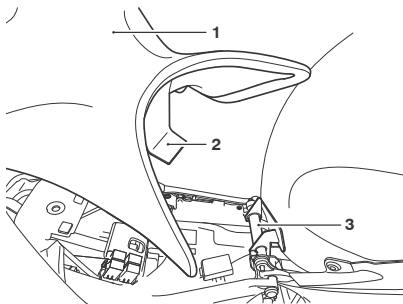

1. Rider's seat
2. Front bracket
3. Fuel tank hinge

- Secure the rider's seat to the seat lock plate with the two fixings.
- Tighten to **9 Nm**.

Note:

- **The fuel tank support is located on the underside of the rider's seat, see page 105.**

Side Stand



The motorcycle is fitted with an interlock system to prevent it from being ridden with the side stand in the down position.

Never attempt to ride with the side stand down or interfere with the interlock mechanism as this will cause a dangerous riding condition leading to loss of motorcycle control and an accident.

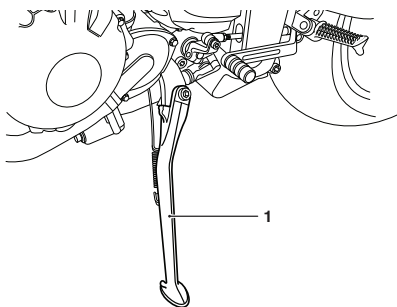

1. Side stand

The motorcycle is equipped with a side stand on which the motorcycle can be parked.

When using the side stand, always turn the handlebars fully to the left and leave the motorcycle in first gear.

Whenever the side stand is used before riding, always make sure that the stand is fully up after first sitting on the motorcycle.

For instructions on safe parking, refer to the 'How to Ride the Motorcycle' section.

Universal Serial Bus (USB) Socket

Warning

The USB socket is not waterproof unless the waterproof cap is installed. Do not connect electronic devices whilst it is raining.

Water in the USB socket could lead to an electrical problem, resulting in motorcycle damage, loss of motorcycle control and an accident.

Caution

Do not leave the ignition switch in the ON position unless the engine is running as this will discharge the battery.

Caution

Make sure that all electronic devices and cables are safely secured under the seat when riding.

Make sure there is sufficient space surrounding any electronic devices for the seat to close without causing any damage to the electronic device or the motorcycle.

The Universal Serial Bus (USB) socket allows a 5 Volt USB connection for charging electronic devices such as mobile phones, cameras and GPS devices.

Loads up to a maximum of 2 Amps can be connected to the USB socket.

To access the USB socket:

- Remove the passenger seat, see page 70.
- The USB socket is located in the centre.

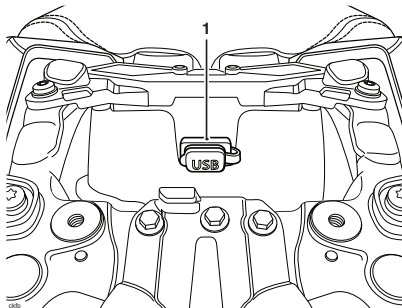

1. USB Port Socket

- Remove the cap.
- Insert the relevant USB adaptor cable into the USB port socket.

Note:

- **Adaptor cables are not supplied with the motorcycle.**

General Information

Tool Kit and Owner's Handbook

The tool kit and Owner's Handbook are located under the rider's seat.

Running-In



Running-in is the name given to the process that occurs during the first hours of a new vehicle's operation.

In particular, internal friction in the engine will be higher when components are new. Later on, when continued operation of the engine has ensured that the components have 'bedded in', this internal friction will be greatly reduced.

A period of careful running-in will ensure lower exhaust emissions, and will optimise performance, fuel economy and longevity of the engine and other motorcycle components.

During the first 500 miles (800 km):

- Do not use full throttle;
- Avoid high engine speeds at all times;
- Avoid riding at one constant engine speed, whether fast or slow, for a long period of time;
- Avoid aggressive starts, stops, and rapid accelerations, except in an emergency;
- Do not ride at speeds greater than 3/4 of maximum speed.

From 500 to 1,000 miles (800 to 1,500 km):

- Engine speed can gradually be increased to the rev limit for short periods.

Both during and after running-in has been completed:

- Do not overrev the engine when cold;
- Do not let the engine labour. Always downshift before the engine begins to 'struggle';
- Do not ride with engine speeds unnecessarily high. Changing up a gear helps reduce fuel consumption, reduces noise and helps to protect the environment.

Daily Safety Checks



Warning

Failure to perform these checks every day before you ride may result in serious motorcycle damage or an accident causing serious injury or death.



DAILY SAFETY CHECKS AND SEAT CARE
CONTRÔLES DE SÉCURITÉ QUOTIDIEN ET NETTOYAGE DE LA SELLE
COMPROBACIONES DIARIAS Y EL MANTENIMIENTO DE SU ASIENTO
DAGELUKSE VEILIGHEIDSCONTROLES EN ZADELONDERHOUD
TÄGLICHE SICHERHEITSKONTROLLEN UND PFLEGE DES SITZES
DAGLIGA SÄKERHETSKONTROLLER OCH VÅRD AV SADEL
CONTROLLI DI SICUREZZA GIORNALIERI E PULIZIA SELLA
日常安全点検とシートのお手入れ

Check the following items each day before you ride. The time required is minimal, and these checks will help ensure a safe, reliable ride.

If any irregularities are found during these checks, refer to the Maintenance and Adjustment section or see your authorised Triumph dealer for the action required to return the motorcycle to a safe operating condition.

Check:

Fuel: Adequate supply in tank, no fuel leaks (see page 67).

Engine Oil: Correct level on dipstick. Add correct specification oil as required. No leaks from the engine or oil cooler (see page 99).

Drive Chain: Correct adjustment (see page 108).

Tyres/Wheels: Correct inflation pressures (when cold). Tread depth/wear, tyre/wheel damage, punctures etc. (see page 127).

Nuts, Bolts, Fasteners: Visually check that steering and suspension components, axles, and all controls are properly tightened or fastened. Inspect all areas for loose/damaged fixings.

Steering Action: Smooth but not loose from lock to lock. No binding of any of the control cables (see page 117).

Brakes: Pull the brake lever and push the brake pedal to check for correct resistance. Investigate any lever/pedal where the travel is excessive before meeting resistance, or if either control feels spongy in operation (see page 111).

Brake Pads: There should be more than 1.0 mm of friction material remaining on the front brake pads and more than 1.5 mm for the rear (see page 111).

Brake Fluid Levels: No brake fluid leakage. Brake fluid levels must be between the MAX and MIN marks on both reservoirs (see page 113).

Front Forks: Smooth action. No leaks from fork seals (see page 119).

Throttle: Throttle grip free play 2 - 3 mm at all steering angles. Make sure that the throttle grip returns to the idle position without sticking (see page 60).

Clutch: Smooth operation and correct cable free play (see page 107) at all steering angles.

Coolant: No coolant leakage. Check the coolant level in the expansion tank (when the engine is cold) (see page 102).

Electrical Equipment: All lights and horn function correctly (see page 51).

Engine Stop: Stop switch turns the engine off (see page 77).

Stand: Returns to the fully up position by spring tension. Return springs not weak or damaged (see page 72).

How to Ride the Motorcycle

HOW TO RIDE THE MOTORCYCLE

Table of Contents

Stopping the Engine.....	77
Stopping the Engine.....	77
Starting the Engine.....	78
Starting the Engine.....	79
Moving Off.....	80
Changing Gears.....	80
Triumph Shift Assist (if fitted).....	81
Braking.....	82
ABS (Anti-Lock Brake System).....	83
Optimised Cornering ABS.....	84
Parking.....	85
Considerations for High Speed Operation.....	87

Stopping the Engine

Speed Triple RS

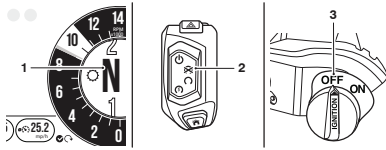

1. Neutral indicator light
2. Engine stop switch - STOP position
3. Master ignition switch - OFF position (if fitted)

To stop the engine:

- Close the throttle completely.
- Select neutral.
- Place the engine stop switch in the STOP position.
- Turn the master ignition switch to the OFF position (if fitted).
- Select first gear.
- Support the motorcycle on a firm, level surface with the side stand.
- Lock the steering.

⚠ Caution

Do not leave the ignition switched on with the engine stopped. This will cause electrical damage.

Stopping the Engine

Speed Triple S

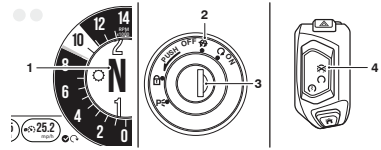

1. Neutral indicator light
2. OFF position
3. Ignition switch
4. Engine stop switch - STOP position

To stop the engine:

- Close the throttle completely.
- Select neutral.
- Turn the ignition switch off.
- Place the engine stop/start switch in the STOP position.
- Select first gear.
- Support the motorcycle on a firm, level surface with the side stand.
- Lock the steering.

⚠ Caution

The engine should normally be stopped by turning the ignition switch to the OFF position.

The engine stop switch is for emergency use only.

Do not leave the ignition switched on with the engine stopped. This will cause electrical damage.

How to Ride the Motorcycle

Starting the Engine

Warning

Never start the engine or run the engine in a confined area.

Exhaust fumes are poisonous and can cause loss of consciousness and death within a short period of time.

Always operate your motorcycle in the open air or in an area with adequate ventilation.

Caution

The low oil pressure warning light should go out shortly after the engine starts.

If the low oil pressure warning light stays on after starting the engine, stop the engine immediately and investigate the cause.

Running the engine with low oil pressure will cause severe engine damage.

To start the engine:

- Make sure that the master ignition switch (if fitted) is turned to the ON position, see page 51.
- Pull the clutch lever fully into the handlebar.
- Press and hold the QUICK START position on the engine start/stop switch until the engine starts.
- Make sure the transmission is in neutral.

The motorcycle is equipped with starter lockout switches. The switches prevent the electric starter from operating when the transmission is not in neutral with the side stand down.

If the side stand is extended whilst the engine is running, and the transmission is not in neutral then the engine will stop regardless of clutch position.

Note:

- A transponder is fitted within the key to turn off the engine immobiliser. Only have one of the ignition keys near the motorcycle. Having two ignition keys near the motorcycle may interrupt the signal between the transponder and the engine immobiliser. In this situation the engine immobiliser will remain active until one of the ignition keys is removed.

Speed Triple RS

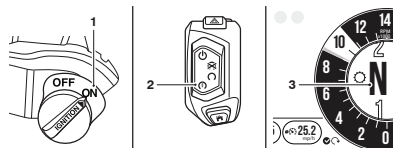

1. Master ignition switch (if fitted)
2. Engine start/stop switch - QUICK START position
3. Neutral indicator light

Starting the Engine

Warning

Never start the engine or run the engine in a confined area.

Exhaust fumes are poisonous and can cause loss of consciousness and death within a short period of time.

Always operate your motorcycle in the open air or in an area with adequate ventilation.

Caution

The low oil pressure warning light should go out shortly after the engine starts.

If the low oil pressure warning light stays on after starting the engine, stop the engine immediately and investigate the cause.

Running the engine with low oil pressure will cause severe engine damage.

To start the engine:

- Check that the engine stop switch is in the RUN position.
- Make sure the transmission is in neutral.
- Turn the ignition switch on.
- Pull the clutch lever fully into the handlebar.
- Leaving the throttle fully closed, push the START position on the engine start/stop switch until the engine starts.

The motorcycle is equipped with starter lockout switches. The switches prevent the electric starter from operating when the transmission is not in neutral with the side stand down.

If the side stand is extended whilst the engine is running, and the transmission is not in neutral then the engine will stop regardless of clutch position.

Note:

- A transponder is fitted within the key to turn off the engine immobiliser. Only have one of the ignition keys near the ignition switch. Having two ignition keys near the switch may interrupt the signal between the transponder and the engine immobiliser. In this situation the engine immobiliser will remain active until one of the ignition keys is removed.

Speed Triple S

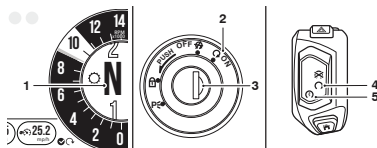

1. Neutral indicator light
2. ON position
3. Ignition switch
4. Engine start/stop switch - RUN position
5. Engine start/stop switch - START position

How to Ride the Motorcycle

Moving Off

To move the motorcycle:

- Pull in the clutch lever and select first gear.
- Open the throttle a little and let out the clutch lever slowly.
- As the clutch starts to engage, open the throttle a little more, allowing enough engine speed to avoid stalling.

Changing Gears

! Warning

Take care to avoid opening the throttle too far or too fast in any of the lower gears as this can lead to the front wheel lifting from the ground (pulling a 'wheelie') and to the rear tyre breaking traction (wheel spin).

Always open the throttle cautiously, particularly if you are unfamiliar with the motorcycle, as a 'wheelie' or loss of traction will cause loss of motorcycle control and an accident.

! Warning

Do not change to a lower gear at speeds that will cause excessive engine rpm (r/min). This can lock the rear wheel causing loss of control and an accident. Engine damage may also be caused.

Changing down should be done such that low engine speeds will be ensured.

Note:

- The gear change mechanism is the 'positive stop' type. This means that, for each movement of the gear change pedal, you can only select each gear, one after the other, in ascending or descending order.

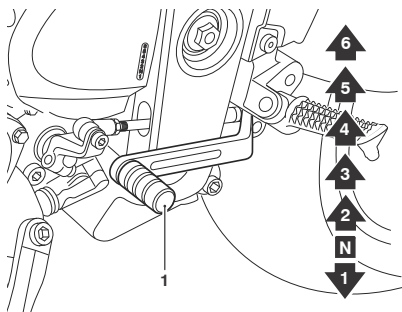

1. Gear change pedal

To change gears:

- Close the throttle while pulling in the clutch lever.
- Change into the next higher or lower gear.
- Open the throttle part way, while releasing the clutch lever.
- Always use the clutch when changing gear.

Triumph Shift Assist (if fitted)

Triumph Shift Assist adjusts the engine torque to allow gears to engage, without closure of the throttle twist grip or operation of the clutch.

This feature works for both up shifts and down shifts of gear.

The clutch must be used for stopping and pulling away.

Triumph Shift Assist will not operate if:

- The clutch is applied.
- An up shift is attempted by mistake when in 6th gear.
- A down shift is attempted by mistake when in 1st gear.
- An up shift is attempted at very low engine speeds.
- A down shift is attempted at very high engine speeds.
- Cruise control is active.

Triumph Shift Assist will be disabled when riding, if a Triumph Shift Assist system malfunction is present.

Use a positive pedal force and release your foot from the gear lever between gear changes to make sure there is a smooth gear change.

For more information on enabling and disabling the Triumph Shift Assist functionality, see page **39**.

Braking

Warning

WHEN BRAKING, OBSERVE THE FOLLOWING:

Close the throttle completely, leaving the clutch engaged to allow the engine to help slow down the motorcycle.

Change down one gear at a time such that the transmission is in first gear when the motorcycle comes to a complete stop.

When stopping, always apply both brakes at the same time. Normally the front brake should be applied a little more than the rear.

Change down or fully disengage the clutch as necessary to keep the engine from stalling.

Never lock the brakes, as this may cause loss of control of the motorcycle and an accident.

Warning

For emergency braking, disregard down changing, and concentrate on applying the front and rear brakes as hard as possible without skidding. Riders should practice emergency braking in a traffic-free area. (See the ABS section on page **83**.)

Triumph strongly recommends that all riders take a course of instruction, which includes advice on safe brake operation. Incorrect brake technique could result in loss of control and an accident.

How to Ride the Motorcycle

⚠ Warning

For your safety, always exercise extreme caution when braking, (whether or not ABS is fitted), accelerating or turning as any incautious action can cause loss of control and an accident. Independent use of the front or rear brakes reduces overall braking performance. Extreme braking may cause either wheel to lock, reducing control of the motorcycle and causing an accident (see ABS warning).

When possible, reduce speed or brake before entering a turn as closing the throttle or braking in mid-turn may cause wheel slip leading to loss of control and an accident.

When riding in wet or rainy conditions, or on loose surfaces, the ability to manoeuvre and stop will be reduced. All of your actions should be smooth under these conditions. Sudden acceleration, braking or turning may cause loss of control and an accident.

⚠ Warning

When descending a long, steep gradient, use engine braking by down changing and use the brakes intermittently. Continuous brake application can overheat the brakes and reduce their effectiveness.

Riding with your foot on the brake pedal or your hands on the brake lever may actuate the brake light, giving a false indication to other road users. It may also overheat the brake, reducing braking effectiveness.

⚠ Warning Continued

Do not coast with the engine switched off, and do not tow the motorcycle. The transmission is pressure-lubricated only when the engine is running. Inadequate lubrication may cause damage or seizure of the transmission, which can lead to sudden loss of motorcycle control and an accident.

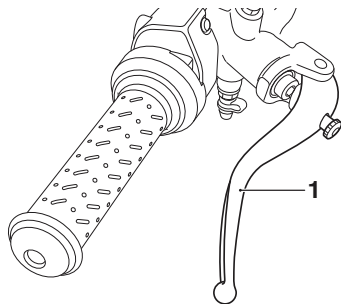

1. Front brake lever

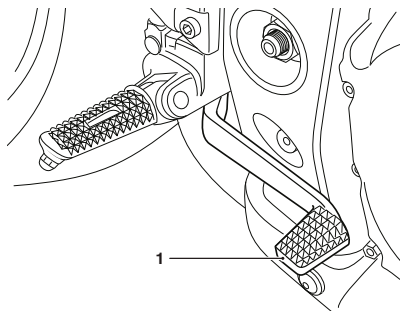

1. Rear brake pedal

ABS (Anti-Lock Brake System)



ABS prevents the wheels from locking, therefore maximising the effectiveness of the braking system in emergencies and when riding on slippery surfaces. The potentially shorter braking distances ABS allows under certain conditions are not a substitute for good riding practice.

Always ride within the legal speed limit.

Never ride without due care and attention and always reduce speed in consideration of weather, road and traffic conditions.

Take care when cornering. If the brakes are applied in a corner, ABS will not be able to counteract the weight and momentum of the motorcycle. This can result in loss of control and an accident.

Under some circumstances it is possible that a motorcycle equipped with ABS may require a longer stopping distance than an equivalent motorcycle without ABS.

ABS Warning Light



When the ignition switch is turned on, it is normal for the ABS warning light to flash on and off (see page 22). If the ABS warning light is constantly illuminated it indicates that the ABS function is not available because:

- the ABS has been disabled by the rider;
- the ABS has a malfunction that requires investigation.

If the warning light becomes illuminated while riding, it indicates that the ABS has a malfunction that requires investigation.

Note:

- **Normally, the rider will perceive ABS operation as a harder feel or a pulsation of the brake lever and pedal. As the ABS is not an integrated braking system and it does not control both the front and rear brake at the same time, this pulsation may be felt in the lever, the pedal or both.**
- **The ABS may be activated by sudden upward or downward changes in the road surface.**

How to Ride the Motorcycle

Warning

If the ABS is not functioning, the brake system will continue to function as a non-ABS braking system.

Do not continue to ride for longer than is necessary with the indicator light illuminated. In this situation, braking too hard will cause the wheels to lock resulting in loss of control and an accident.

Contact an authorised Triumph dealer as soon as possible to have the fault checked and rectified.

Warning

The ABS warning light will illuminate when the rear wheel is driven at high speed for more than 30 seconds when the motorcycle is on a stand. This reaction is normal.

When the ignition is switched off and the motorcycle is re-started, the warning light will illuminate until the motorcycle reaches a speed exceeding 19 mph (30 km/h).

Warning

The ABS computer operates by comparing the relative speed of the front and rear wheels.

Use of non-recommended tyres can affect wheel speed and cause the ABS function not to operate, potentially leading to loss of control and an accident in conditions where the ABS would normally function.

Optimised Cornering ABS

Note:

- **Only Speed Triple RS is equipped with the optimised cornering ABS.**

The optimised cornering ABS is a system designed to give the rider increased control should the ABS be activated whilst the motorcycle is leaning in a corner.

A sensor constantly monitors the lean angle of the motorcycle. If the motorcycle is leaning in a corner and the ABS is activated, the system will use the lean angle measurement to apply the ABS in a manner most suitable to help the rider maintain motorcycle control.

Warning

The optimised cornering ABS is a system designed to help the rider in emergency braking situations.

The system is designed to give the rider increased control should the ABS be activated whilst the motorcycle is leaning in a corner.

The potential increased control that the optimised cornering braking system allows under certain conditions is not a substitute for good riding practice.

Warning

Always ride within the legal speed limit. Never ride without due care and attention and always reduce speed in consideration of weather, surface and traffic conditions.

Take care when cornering.

If the motorcycle is leaning in a corner and the ABS is activated, the optimised cornering ABS will use the lean angle measurement from a sensor to apply the ABS in a manner most suitable to help the rider maintain motorcycle control. The optimised cornering ABS will not however be able to fully counteract the weight and momentum of the motorcycle and braking too hard whilst cornering may result in loss of motorcycle control and an accident.

Under some circumstances it is possible that a motorcycle equipped with optimised cornering ABS may require a longer stopping distance than an equivalent motorcycle without ABS, or an equivalent motorcycle equipped with ABS but not equipped with optimised cornering ABS.

Warning

If the optimised cornering ABS is not functioning, the ABS warning light will illuminate and a message will be shown.

In this situation, the ABS will continue to operate but without the optimised cornering function, provided that:

- There are no other ABS faults
- The ABS has not been disabled by the rider (see Bike Setup on page **40** or Riding Mode Configuration on page **38**).

Do not continue to ride for longer than is necessary with the warning light illuminated. In the event of a fault, contact an authorised Triumph dealer as soon as possible to have the fault checked and rectified.

In this situation, braking too hard during cornering may result in loss of motorcycle control and an accident.

Parking

Warning

Do not park on a soft or on a steeply inclined surface.

Parking under these conditions may cause the motorcycle to fall over causing damage to property and personal injury.

How to Ride the Motorcycle

! Warning

Petrol is extremely flammable and can be explosive under certain conditions. If parking inside a garage or other structure, be sure it is well ventilated and the motorcycle is not close to any source of flame or sparks. This includes any appliance with a pilot light.

Failure to follow the above advice may cause a fire resulting in damage to property or personal injury.

! Warning

The engine and exhaust system will be hot after riding.

DO NOT park where pedestrians and children are likely to touch the motorcycle.

Touching any part of the engine or exhaust system when hot may cause unprotected skin to become burnt.

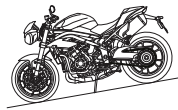
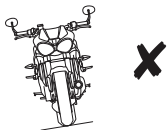
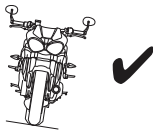

ccms_2

To park the motorcycle:

- Select neutral and turn the ignition switch to the OFF position.
- Lock the steering to help prevent theft.
- Always park on a firm, level surface to prevent the motorcycle from falling.
- When parking on a hill, always park facing uphill to prevent the motorcycle from rolling off the stand. Engage first gear to prevent the motorcycle from moving.
- On a lateral (sideways) incline, always park such that the incline naturally pushes the motorcycle towards the side stand.
- Do not park on a lateral (sideways) incline of greater than 6° and never park facing downhill.

Note:

- **Speed Triple S Only**
- **When parking near traffic at night, or when parking in a location where parking lights are required by law, leave the tail, license plate and position lights on by turning the ignition switch to P (Park).**
- **Do not leave the switch in the P position for long periods of time as this will discharge the battery.**

Considerations for High Speed Operation

Warning

This Triumph motorcycle should be operated within the legal speed limits for the particular road travelled.

Operating a motorcycle at high speeds can be potentially dangerous since the time available to react to given traffic situations is greatly reduced as road speed increases.

Always reduce speed in consideration of weather and traffic conditions.

Warning

Only operate this Triumph motorcycle at high speed in closed-course on-road competition or on closed-course race-tracks. High speed operation should only then be attempted by riders who have been instructed in the techniques necessary for high speed riding and are familiar with the motorcycle's characteristics in all conditions.

High speed operation in any other circumstances is dangerous and will lead to loss of motorcycle control and an accident.

Warning

The handling characteristics of a motorcycle at high speed may vary from those you are familiar with at legal road speeds. Do not attempt high speed operation unless you have received sufficient training and have the required skills as a serious accident may result from incorrect operation.

Warning

The items listed below are extremely important and must never be neglected. A problem, which may not be noticed at normal operating speeds, may be greatly exaggerated at high speeds.

General

Make sure that the motorcycle has been maintained according to the scheduled maintenance chart.

Steering

Check that the handlebar turns smoothly without excessive free play or tight spots. Make sure that the control cables do not restrict the steering in any way.

Luggage

Make sure that any luggage containers are closed, locked and securely fitted to the motorcycle.

Brakes

Check that the front and rear brakes are functioning correctly.

How to Ride the Motorcycle

Tyres

High speed operation is hard on tyres, and tyres that are in good condition are crucial to riding safely. Examine their overall condition, inflate to the correct pressure (when the tyres are cold), and check the wheel balance. Securely fit the valve caps after checking tyre pressures. Observe the information given in the maintenance and specification sections on tyre checking and tyre safety.

Fuel

Have sufficient fuel for the increased fuel consumption that will result from high speed operation.



Caution

In many countries, the exhaust system for this model is fitted with a catalytic converter to help reduce exhaust emission levels.

The catalytic converter can be permanently damaged if the motorcycle is allowed to run out of fuel or if the fuel level is allowed to get very low.

Always make sure you have adequate fuel for your journey.

Engine Oil

Check that the engine oil level is correct. Make sure that the correct grade and type of oil is used when topping up.

Drive Chain

Make sure that the drive chain is correctly adjusted and lubricated. Inspect the chain for wear and damage.

Coolant

Check that the coolant level is at the upper level line in the expansion tank. Always check the level with the engine cold.

Electrical Equipment

Make sure that all electrical equipment such as the headlight, rear/brake light, direction indicators and horn all work correctly.

Miscellaneous

Visually check that all fixings are tight.

ACCESSORIES, LOADING AND PASSENGERS

The addition of accessories and carriage of additional weight can affect the motorcycle's handling characteristics causing changes in stability and necessitating a reduction in speed. The following information has been prepared as a guide to the potential hazards of adding accessories to a motorcycle and carrying passengers and additional loads.

Accessories

Warning

Do not install accessories or carry luggage that impairs the control of the motorcycle.

Make sure that you have not adversely affected any lighting component, road clearance, banking capability (i.e. lean angle), control operation, wheel travel, front fork movement, visibility in any direction, or any other aspect of the motorcycle's operation.

Warning

Never ride an accessory equipped motorcycle, or a motorcycle carrying a payload of any kind, at speeds above 80 mph (130 km/h). In either/both of these conditions, speeds in excess of 80 mph (130 km/h) should not be attempted even where the legal speed limit permits this.

Warning Continued

The presence of accessories and/or payload will cause changes in the stability and handling of the motorcycle.

Failure to allow for changes in motorcycle stability may lead to loss of motorcycle control and an accident. When riding at high speed, always be aware that various motorcycle configuration and environmental factors can adversely affect the stability of your motorcycle. For example:

- Incorrectly balanced loads on both sides of the motorcycle
- Incorrectly adjusted front and rear suspension settings
- Incorrectly adjusted tyre pressures
- Excessively or unevenly worn tyres
- Side winds and turbulence from other vehicles
- Loose clothing.

Remember that the 80 mph (130 km/h) absolute limit will be reduced by the fitting of non-approved accessories, incorrect loading, worn tyres, overall motorcycle condition and poor road or weather conditions.

Accessories, Loading and Passengers

Warning

Owners should be aware that the only approved parts, accessories and conversions for any Triumph motorcycle are those which carry official Triumph approval and are fitted to the motorcycle by an authorised dealer.

In particular, it is extremely hazardous to fit or replace parts or accessories whose fitting requires the dismantling of, or addition to, either the electrical or fuel systems and any such modification could cause a safety hazard.

The fitting of any non-approved parts, accessories or conversions may adversely affect the handling, stability or other aspect of the motorcycle operation that may result in an accident causing injury or death.

Triumph does not accept any liability whatsoever for defects caused by the fitting of non-approved parts, accessories or conversions or the fitting of any approved parts, accessories or conversions by non-approved personnel.

Loading

Warning

Incorrect loading may result in an unsafe riding condition leading to an accident.

Always make sure that any loads carried are evenly distributed on both sides of the motorcycle. Make sure that the load is correctly secured such that it will not move around while the motorcycle is in motion.

Evenly distribute the load within each pannier. Pack heavy items at the bottom and on the inboard side of the pannier.

Always check the load security regularly (though not while the motorcycle is in motion) and make sure that the load does not extend beyond the rear of the motorcycle.

Never exceed the maximum vehicle loading weight of 196 kg (432 lbs).

Warning

Never attempt to store any items between the frame and the fuel tank. This can restrict the steering and will cause loss of control leading to an accident.

Weight attached to the handlebar or front fork will increase the mass of the steering assembly and can result in loss of steering control leading to an accident.

Accessories, Loading and Passengers

Warning

If the passenger seat is used to carry small objects, they must not exceed 3 kg (6.6lbs) in weight, must not impair control of the motorcycle, must be securely attached and must not extend beyond the rear or sides of the motorcycle.

Carrying objects in excess of 3 kg (6.6lbs) in weight, that are insecure, impair control or extend beyond the rear or sides of the motorcycle may lead to loss of motorcycle control and an accident.

Even if small objects are correctly loaded onto the passenger seat, the maximum speed of the motorcycle must be reduced to 80 mph (130 km/h).

Passengers

Warning

The handling and braking capabilities of a motorcycle will be affected by the presence of a passenger. The rider must make allowances for these changes when operating the motorcycle with a passenger and should not attempt such operation unless trained to do so and without becoming familiar and comfortable with the changes in motorcycle operating characteristics that this brings about.

Motorcycle operation without making allowances for the presence of a passenger could lead to loss of motorcycle control and an accident.

Warning

Do not carry a passenger unless he or she is tall enough to reach the footrests provided.

A passenger who is not tall enough to reach the footrests will be unable to sit securely on the motorcycle and may cause instability leading to loss of control and an accident.

Accessories, Loading and Passengers

Warning

Your passenger should be instructed that he or she can cause loss of motorcycle control by making sudden movements or by adopting an incorrect seated position.

The rider should instruct the passenger as follows:

It is important that the passenger sits still while the motorcycle is in motion and does not interfere with the operation of the motorcycle.

To keep his or her feet on the passenger footrests and to firmly hold onto the grab handles or the rider's waist or hips.

Advise the passenger to lean with the rider when travelling around corners and not to lean unless the rider does so.

Warning

Do not carry animals on your motorcycle.

An animal could make sudden and unpredictable movements that could lead to loss of motorcycle control and an accident.

MAINTENANCE

Table of Contents

Scheduled Maintenance	95
Scheduled Maintenance Chart	97
Engine Oil	99
Engine Oil Level Inspection	99
Engine Oil and Oil Filter Change	100
Disposal of Used Engine Oil and Oil Filters	101
Engine Oil Specification and Grade	101
Cooling System	102
Corrosion Inhibitors	103
Coolant Level Inspection	103
Coolant Level Adjustment	104
Coolant Change	105
Fuel Tank	105
Raising the Fuel Tank	105
Lowering the Fuel Tank	106
Clutch	107
Clutch Inspection	107
Clutch Adjustment	107
Drive Chain	108
Drive Chain Lubrication	108
Drive Chain Free Movement Inspection	109
Drive Chain Free Movement Adjustment	109
Chain and Sprocket Wear Inspection	110
Brakes	111
Brake Wear Inspection	111
Breaking-in New Brake Pads and Discs	112
Brake Pad Wear Compensation	113
Disc Brake Fluid	113
Brake Fluid Level Inspection and Adjustment	114
Brake Light Switches	115
Mirrors	116
Steering/Wheel Bearings	117
Steering Inspection	118
Wheel Bearings Inspection	118
Suspension	119
Front Fork Inspection	119

Maintenance

Suspension Setting Chart - Speed Triple S	120
Suspension Setting Chart - Speed Triple RS	121
Front Suspension Adjustment	122
Spring Preload Adjustment - All Models	122
Rebound Damping Adjustment - Speed Triple S	122
Rebound Damping Adjustment - Speed Triple RS	123
Compression Damping Adjustment - Speed Triple S	123
Compression Damping Adjustment - Speed Triple RS	124
Rear Suspension Adjustment	124
Rebound Damping Adjustment - Speed Triple S	124
Rebound Damping Adjustment - Speed Triple RS	125
Compression Damping Adjustment - Speed Triple S	125
Compression Damping Adjustment - Speed Triple RS	126
Spring Preload - All Models	126
Tyres	127
Tyre Inflation Pressures	127
Tyre Pressure Monitoring System (if fitted)	127
Tyre Wear	128
Minimum Recommended Tread Depth	128
Tyre Replacement	129
Battery	131
Battery Removal	132
Battery Disposal	132
Battery Maintenance	132
Battery Discharge	133
Battery Discharge During Storage and Infrequent Use of the Motorcycle	133
Battery Charging	133
Battery Installation	134
Fuse Boxes	135
Fuse Identification	135
Front Fuse Box	135
Rear Fuse Box	136
Main Fuse	136
Headlights	137
Headlight Adjustment - Vertical	138
Headlight Bulb Replacement	138
Daytime Running Lights (DRL) (if fitted)	140
Direction Indicator Lights	141
Rear Light	141
License Plate Light	141

Scheduled Maintenance

Warning

Triumph Motorcycles cannot accept any responsibility for damage or injury resulting from incorrect maintenance or improper adjustment carried out by the owner.

Since incorrect or neglected maintenance can lead to a dangerous riding condition, always have an authorised Triumph dealer carry out the scheduled maintenance of this motorcycle.

Warning

All maintenance is vitally important and must not be neglected. Incorrect maintenance or adjustment may cause one or more parts of the motorcycle to malfunction. A malfunctioning motorcycle may lead to loss of control and an accident.

Weather, terrain and geographical location affect maintenance. The maintenance schedule should be adjusted to match the particular environment in which the vehicle is used and the demands of the individual owner.

Special tools, knowledge and training are required in order to correctly carry out the maintenance items listed in the scheduled maintenance chart. Only an authorised Triumph dealer will have this knowledge and equipment.

Since incorrect or neglected maintenance can lead to a dangerous riding condition, always have an authorised Triumph dealer carry out the scheduled maintenance of this motorcycle.

To maintain the motorcycle in a safe and reliable condition, the maintenance and adjustments outlined in this section must be carried out as specified in the schedule of daily checks, and also in line with the scheduled maintenance chart. The information that follows describes the procedures to follow when carrying out the daily checks and some simple maintenance and adjustment items.

Maintenance

Scheduled maintenance may be carried out by your authorised Triumph dealer in three ways; annual maintenance, mileage based maintenance or a combination of both, depending on the mileage the motorcycle travels each year.

1. Motorcycles travelling less than 6,000 miles (10,000 km) per year must be maintained annually. In addition to this, mileage based items require maintenance at their specified intervals, as the motorcycle reaches this mileage.
2. Motorcycles travelling approximately 6,000 miles (10,000 km) per year must have the annual maintenance and the specified mileage based items carried out together.
3. Motorcycles travelling more than 6,000 miles (10,000 km) per year must have the mileage based items maintained as the motorcycle reaches the specified mileage. In addition to this, annual based items will require maintenance at their specified annual intervals.

In all cases maintenance must be carried out at or before the specified maintenance intervals shown. Consult an authorised Triumph dealer for advice on which maintenance schedule is most suitable for your motorcycle.

Triumph Motorcycles cannot accept any responsibility for damage or injury resulting from incorrect maintenance or improper adjustment.

Scheduled Maintenance Chart

Operation Description	Odometer Reading in Miles (Km) or Time Period, whichever comes first					
		First Service	Annual Service	Mileage Based Service		
	Every	500 (800) 1 month	Year	6,000 and 18,000 (10,000 and 30,000)	12,000 (20,000)	24,000 (40,000)
Lubrication						
Engine and oil cooler - check for leaks	Day	*	*	*	*	*
Engine oil - renew	-	*	*	*	*	*
Engine oil filter - renew	-	*	*	*	*	*
Fuel System and Engine Management						
Autoscan - Carry out a full Autoscan using the Triumph Diagnostic Tool (print a customer copy)	-	*	*	*	*	*
Fuel system - check hoses for chafing, cracks or damage	-			*	*	*
Fuel system - Check for leaks	Day	*	*	*	*	*
Air cleaner - renew	-				*	*
Throttle bodies - balance	-			*	*	*
Fuel hoses - renew	Every four years, regardless of mileage					
Evaporative loss hoses - renew	Every four years, regardless of mileage					
Secondary air injection system - check	-				*	*
Ignition System						
Spark plugs - check	-			*		
Spark plugs - renew	-				*	*
Cooling System						
Cooling system - check for leaks	Day	*	*	*	*	*
Cooling system - check hoses for chafing, cracks or damage. Replace hoses if necessary	-			*	*	*
Coolant level - check/adjust	Day	*	*	*	*	*
Coolant - renew	Every 3 years regardless of mileage					
Engine						
Clutch cable - check function and adjust as necessary	Day	*	*	*	*	*
Valve clearances - check/adjust	-				*	*
Camshaft timing - check/adjust	-				*	*
Wheels and Tyres						
Wheels - inspect for damage	Day	*	*	*	*	*
Rear wheel needle roller bearing - lubricate	-				*	*
Wheel bearings - check for wear/smooth operation	-	*	*	*	*	*
Tyre wear/tyre damage - check	Day	*	*	*	*	*
Tyre pressures - check/adjust	Day	*	*	*	*	*
Electrical						
All lights, instruments and electrical systems - check	Day	*	*	*	*	*
Steering and Suspension						
Steering - check for free operation	Day	*	*	*	*	*

Maintenance

Operation Description	Odometer Reading in Miles (Km) or Time Period, whichever comes first					
		First Service	Annual Service	Mileage Based Service		
	Every	500 (800) 1 month	Year	6,000 and 18,000 (10,000 and 30,000)	12,000 (20,000)	24,000 (40,000)
Headstock bearings - check/adjust	-		*	*	*	*
Headstock bearings - lubricate	-				*	*
Front and rear suspension - check for leaks/smooth operation	Day	*	*	*	*	*
Fork oil - renew	-					*
Rear suspension linkage - lubricate	-				*	*
Brakes						
Brake fluid levels - check	Day	*	*	*	*	*
Brake fluid - renew	Every 2 years regardless of mileage					
Brake pads - check wear levels	Day	*	*	*	*	*
Brake master cylinders - check for fluid leaks	-	*	*	*	*	*
Brake calipers - check for fluid leaks and seized pistons	-	*	*	*	*	*
ABS and immobiliser ECMs - check for stored DTCs	-	*	*	*	*	*
Drive Chain						
Drive chain - lubricate	Every 200 miles (300 km)					
Drive chain - wear check	Every 500 miles (800 km)					
Drive chain slack - check/adjust	Day	*	*	*	*	*
Drive chain rubbing strip - check	-	*	*	*	*	*
General						
Engine ECM, Instruments and Keyless ECM - check for latest calibration download using the Triumph diagnostic tool						
Fasteners - inspect visually for security	Day	*	*	*	*	*
Bank angle indicators - inspect visually for wear	Day	*	*	*	*	*
Side stand/Centre stand - check operation	Day	*	*	*	*	*
Side stand pivot - clean/grease	-			*	*	*
Carry out all outstanding Service Bulletin and warranty work	-	*	*	*	*	*
Carry out road test	-	*	*	*	*	*
Complete the service record book and reset the service indicator	-	*	*	*	*	*

Engine Oil



Warning

Motorcycle operation with insufficient, deteriorated, or contaminated engine oil will cause accelerated engine wear and may result in engine or transmission seizure. Seizure of the engine or transmission may lead to sudden loss of control and an accident.

In order for the engine, transmission, and clutch to function correctly, maintain the engine oil at the correct level, and change the oil and oil filter in accordance with scheduled maintenance requirements.

Engine Oil Level Inspection

Warning

Never start the engine or run the engine in a confined area. Exhaust fumes are poisonous and can cause loss of consciousness and death within a short period of time.

Always operate your motorcycle in the open-air or in an area with adequate ventilation.

Caution

Running the engine with insufficient oil will cause engine damage. If the low oil pressure indicator remains on, stop the engine immediately and investigate the cause.

Note:

- An accurate indication of the level of oil in the engine is only shown when the engine oil is at normal operating temperature, the motorcycle is upright (not on the side stand) and the filler plug/dipstick has been fully screwed home.

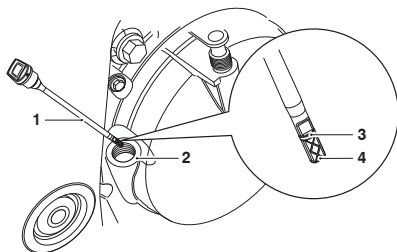

1. Filler plug/dipstick
2. Filler
3. Upper marking
4. Lower marking

Maintenance

To inspect the oil level:

- Start the engine and run at idle for approximately five minutes.
- Stop the engine and wait for three minutes to allow the oil to settle.
- With the motorcycle upright, remove the filler plug/dipstick, wipe the blade clean.
- Replace and screw closed the filler plug/dipstick.
- Remove the filler plug/dipstick.
- The oil level is indicated by lines on the filler plug/dipstick. When full, the indicated oil level must be level with the upper marking on the dipstick.
- If the oil level is below the lower marking, add oil a little at a time until the correct level is reached. Once the correct level is reached, refit the filler plug/dipstick.

Engine Oil and Oil Filter Change

Warning

Prolonged or repeated contact with engine oil can lead to skin dryness, irritation and dermatitis. In addition, used engine oil contains harmful contamination that can lead to skin cancer. Always wear suitable protective clothing and avoid skin contact with used oil.

Warning

The oil may be hot to the touch. Avoid contact with the hot oil by wearing suitable protective clothing, gloves, eye protection, etc. Contact with hot oil may cause the skin to be scalded or burned.

The engine oil and filter must be replaced in accordance with scheduled maintenance requirements.

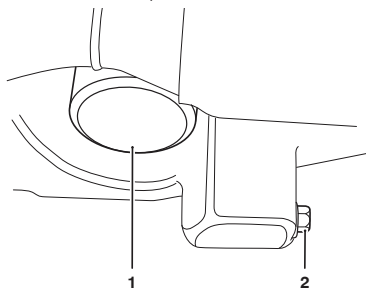

1. Oil filter
2. Oil drain plug

To change the oil and oil filter:

- Warm up the engine thoroughly, and then stop the engine and secure the motorcycle in an upright position on level ground.
- Place an oil drain pan beneath the engine.
- Remove the oil drain plug.
- Unscrew and remove the oil filter using Triumph service tool T3880313. Dispose of the old filter in an environmentally friendly way.
- Apply a thin smear of clean engine oil to the sealing ring of the new oil filter. Fit the oil filter and tighten to **10 Nm**.
- Incorporating a new washer, refit the oil drain plug and tighten to **25 Nm**.
- Fill the engine with a 10W/40 or 10W/50 semi or fully synthetic motorcycle engine oil that meets specification API SH (or higher) and JASO MA, such as Castrol Power 1 Racing 4T 10W-40 (fully synthetic) engine oil, sold as Castrol Power RS Racing 4T 10W-40 (fully synthetic) in some countries.
- Start the engine and allow it to idle for a minimum of 30 seconds.

Caution

Raising the engine speed above idle before the oil reaches all parts of the engine can cause engine damage or seizure. Only raise engine speed after running the engine for 30 seconds to allow the oil to circulate fully.

Caution

If the engine oil pressure is too low, the low oil pressure warning light will illuminate. If this light stays on when the engine is running, stop the engine immediately and investigate the cause. Running the engine with low oil pressure will cause engine damage.

- Make sure that the low oil pressure warning light extinguishes shortly after starting.
- Turn off the ignition, check the oil level using the method previously described, and top up to between the minimum and maximum level lines on the dipstick.

Disposal of Used Engine Oil and Oil Filters

To protect the environment, do not pour oil on the ground, down sewers or drains, or into watercourses. Do not place used oil filters in with general waste. If in doubt, contact your local authority.

Engine Oil Specification and Grade

Triumph's high performance fuel injected engines are designed to use 10W/40 or 10W/50 semi or fully synthetic motorcycle engine oil that meets specification API SH (or higher) and JASO MA, such as Castrol Power 1 Racing 4T 10W-40 (fully synthetic) engine oil, sold as Castrol Power RS Racing 4T 10W-40 (fully synthetic) in some countries.

Maintenance

Refer to the chart below for the correct oil viscosity (10W/40 or 10W/50) to be used in your riding area.

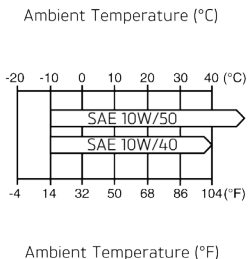

Oil Viscosity Temperature Range

Do not add any chemical additives to the engine oil. The engine oil also lubricates the clutch and any additives could cause the clutch to slip.

Do not use mineral, vegetable, non-detergent oil, castor based oils or any oil not conforming to the required specification. The use of these oils may cause instant, severe engine damage.

Make sure that no foreign matter enters the crankcase during an engine oil change or top up.

Cooling System



To ensure efficient engine cooling, check the coolant level each day before riding the motorcycle, and top up the coolant if the level is low.

Note:

- A year round, Hybrid Organic Acid Technology (known as Hybrid OAT or HOAT) coolant is installed in the cooling system when the motorcycle leaves the factory. It is coloured green, contains a 50% solution of ethylene glycol based antifreeze, and has a freezing point of -35°C (-31°F).

Corrosion Inhibitors

! Warning

HD4X Hybrid OAT coolant contains corrosion inhibitors and antifreeze suitable for aluminium engines and radiators. Always use the coolant in accordance with the instructions of the manufacturer.

Coolant that contains anti-freeze and corrosion inhibitors contains toxic chemicals that are harmful to the human body. Never swallow antifreeze or any of the motorcycle coolant.

Note:

- **HD4X Hybrid OAT coolant, as supplied by Triumph, is premixed and does not need to be diluted prior to filling or topping up the cooling system.**

To protect the cooling system from corrosion, the use of corrosion inhibitor chemicals in the coolant is essential.

If coolant containing a corrosion inhibitor is not used, the cooling system will accumulate rust and scale in the water jacket and radiator. This will block the coolant passages, and considerably reduce the efficiency of the cooling system.

Corrosion Inhibitors

Warning

HD4X Hybrid OAT coolant contains corrosion inhibitors and anti-freeze suitable for aluminium engines and radiators. Always use the coolant in accordance with the instructions of the manufacturer.

Coolant that contains anti-freeze and corrosion inhibitors contains toxic chemicals that are harmful to the human body. Never swallow anti-freeze or any of the motorcycle coolant.

Note:

- **HD4X Hybrid OAT coolant, as supplied by Triumph, is pre-mixed and does not need to be diluted prior to filling or topping up the cooling system.**

To protect the cooling system from corrosion, the use of corrosion inhibitor chemicals in the coolant is essential.

If coolant containing a corrosion inhibitor is not used, the cooling system will accumulate rust and scale in the water jacket and radiator. This will block the coolant passages, and considerably reduce the efficiency of the cooling system.

Coolant Level Inspection

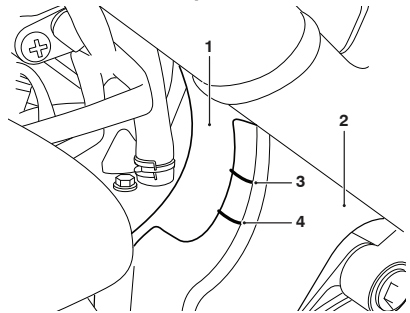

1. Expansion tank
2. Expansion tank cover
3. MAX mark
4. MIN mark

To inspect the coolant level:

- Position the motorcycle on level ground and in an upright position.
- The coolant level within the expansion tank can be inspected on the left hand side of the motorcycle without removing any covers.
- Check the coolant level in the expansion tank. The coolant level must be between the MAX and MIN level marks moulded into the expansion tank cover. If the coolant is below the minimum level, the coolant level must be adjusted.

Maintenance

Coolant Level Adjustment

Warning

Do not remove the radiator pressure cap when the engine is hot.

When the engine is hot, the coolant inside the radiator will be hot and also under pressure.

Contact with this hot, pressurised coolant will cause scalds and skin damage.

Caution

If hard water is used in the cooling system, it will cause scale accumulation in the engine and radiator and considerably reduce the efficiency of the cooling system.

Reduced cooling system efficiency may cause the engine to overheat and suffer severe damage.

To adjust the coolant level:

- Allow the engine to cool.
- To access the expansion tank, raise and support the fuel tank (see page 105).
- Remove the cap from the expansion tank and add coolant mixture through the filler opening until the level reaches the MAX mark on the expansion tank cover.

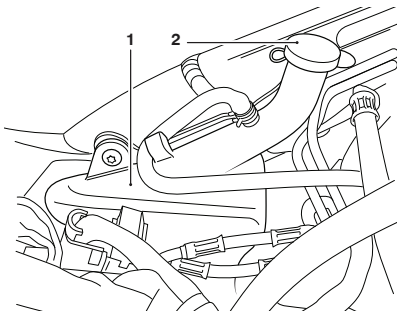

1. Expansion tank
2. Tank cap

- Refit the cap.
- Lower and secure the fuel tank (see page 106).

Note:

- If the coolant level is being checked because the coolant has overheated, also check the level in the radiator and top up if necessary.
- In an emergency, distilled water can be added to the cooling system. However, the coolant must then be drained and replenished with HD4X Hybrid OAT coolant as soon as possible.

Coolant Change

It is recommended that the coolant is changed by an authorised Triumph dealer in accordance with scheduled maintenance requirements.

Radiator and Hoses

Warning

The fan operates automatically when the engine is running. Always keep hands and clothing away from the fan as contact with the rotating fan can cause injury.

Caution

Using high pressure water sprays, such as from a car wash facility or household pressure washer, can damage the radiator fins, cause leaks and impair the radiator's efficiency.

Do not obstruct or deflect airflow through the radiator by installing unauthorised accessories, either in front of the radiator or behind the cooling fan. Interference with the radiator airflow can cause overheating, potentially resulting in engine damage.

Check the radiator hoses for cracks or deterioration, and tension clips for tightness in accordance with scheduled maintenance requirements. Have your authorised Triumph dealer replace any defective items.

Check the radiator grille and fins for obstructions by insects, leaves or mud. Clean off any obstructions with a stream of low pressure water.

Fuel Tank

Note:

- The fuel tank may be raised without being removed completely, for access to the battery and the coolant expansion tank for filling up.

Raising the Fuel Tank

To raise the fuel tank:

- Remove the seats (see page 70) and remove the fuel tank support from its location on the rider's seat base.
- Store the seat as described on page 70.

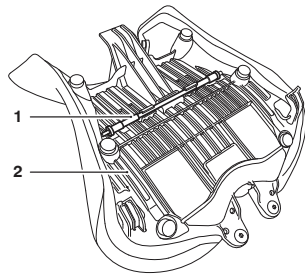

1. Rider's seat
2. Fuel tank support

Maintenance

- Release the three fixings and remove the front panel from the fuel tank.

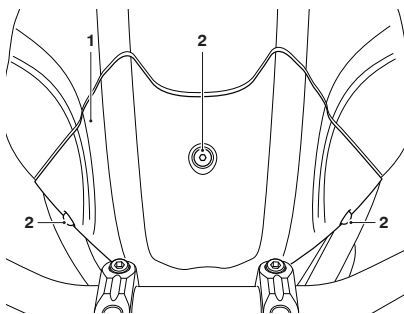

1. Front panel
2. Fixings

- Remove the front fixings for the fuel tank.

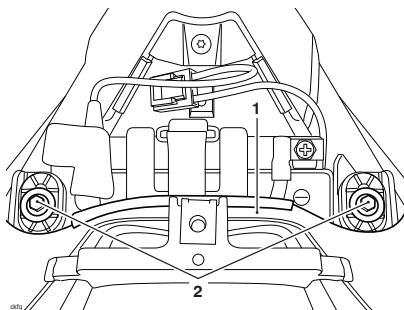

1. Fuel tank
2. Fixings

- Pivot the fuel tank upwards at the front. While holding the fuel tank in the raised position, locate the fuel tank support into the support points on the air box and the fuel tank.

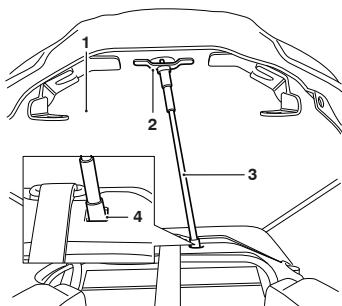

1. Fuel tank support
2. Fuel tank
3. Supporting point, fuel tank
4. Supporting point, air box

Lowering the Fuel Tank

To lower the fuel tank:

- While holding the fuel tank, remove the fuel tank support and lower the fuel tank. Refit the front fixings and tighten to **4 Nm**.
- Refit the front panel and tighten the fixings to **2 Nm**.
- Securely fit the fuel tank support to its location on the seat.
- Refit the seat (see page **70**).

Clutch

The motorcycle is equipped with a cable-operated clutch.

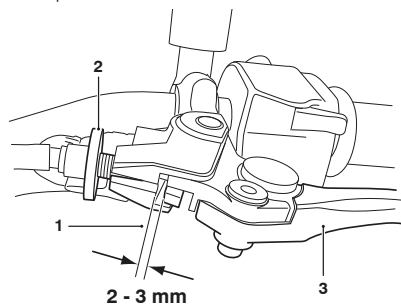

1. Correct setting 2 - 3 mm
2. Adjuster
3. Clutch lever

If the clutch lever has excessive free play, the clutch may not disengage fully. This will cause difficulty in changing gear and selecting neutral. This may cause the engine to stall and make the motorcycle difficult to control. Conversely, if the clutch lever has insufficient free play the clutch may not engage fully, causing the clutch to slip, which will reduce performance and cause premature clutch wear.

Clutch lever free play must be checked in accordance with scheduled maintenance requirements.

Clutch Inspection

Check that there is 2 - 3 mm clutch lever free play at the lever.

If there is an incorrect amount of free play, adjustments must be made.

Clutch Adjustment

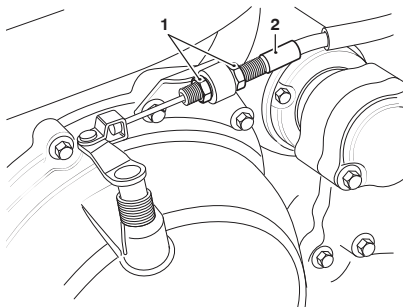

1. Adjuster
2. Clutch cable

To adjust the clutch:

- Turn the adjuster on the clutch lever until the correct amount of clutch lever free play is achieved at all steering angles.
- If correct adjustment cannot be made using the clutch lever adjuster, use the cable adjuster at the lower end of the cable.
- Loosen the adjuster locknut.
- Turn the outer cable adjuster to give 2 - 3 mm of free play at the clutch lever.
- Tighten the locknut.

Maintenance

Drive Chain



Warning

A loose or worn chain, or a chain that breaks or jumps off the sprockets could catch on the engine sprocket or lock the rear wheel.

A chain that snags on the engine sprocket will injure the rider and lead to loss of motorcycle control and an accident.

Similarly, locking the rear wheel will lead to loss of motorcycle control and an accident.

For safety and to prevent excessive wear the drive chain must be checked, adjusted and lubricated in accordance with the scheduled maintenance requirements. Checking, adjustment and lubrication must be carried out more frequently for extreme conditions such as high speed riding, salty or heavily gritted roads.

If the chain is badly worn or incorrectly adjusted (either too loose or too tight) the chain could jump off the sprockets or break. Therefore, always replace worn or damaged chains using genuine Triumph parts supplied by an authorised Triumph dealer.

Drive Chain Lubrication

Lubrication is necessary every 200 miles (300 km) and also after riding in wet weather, on wet roads, or any time that the chain appears dry.

To lubricate the drive chain:

- Use the special drive chain lubricant as recommended in the Specifications section.
- Apply lubricant to the sides of the rollers then allow the motorcycle to stand unused for at least eight hours (overnight is ideal). This will allow the oil to penetrate to the drive chain O-rings etc.
- Before riding, wipe off any excess oil.
- If the drive chain is especially dirty, clean first and then apply oil as mentioned above.

Caution

Do not use a pressure washer to clean the drive chain as this may cause damage to the drive chain components.

Drive Chain Free Movement Inspection

Warning

Before starting work, make sure that the motorcycle is stabilised and adequately supported. This will help prevent injury to the operator or damage to the motorcycle.

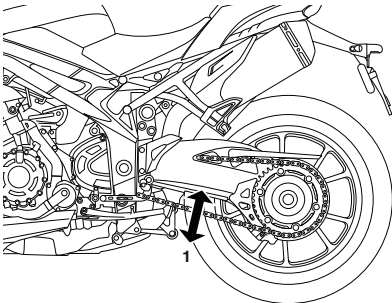

1. Maximum movement position

To inspect the drive chain free movement:

- Place the motorcycle on a level surface and hold it in an upright position with no weight on it.
- Rotate the rear wheel by pushing the motorcycle to find the position where the drive chain is tightest, and measure the vertical movement of the drive chain midway between the sprockets.
- The vertical movement of the drive chain must be in the range 21 - 30 mm.

Drive Chain Free Movement Adjustment

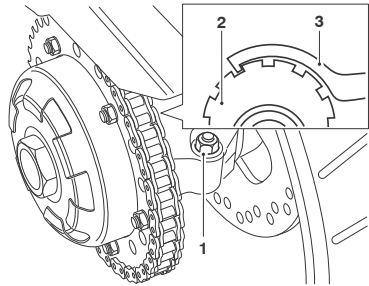

1. Adjuster clamp bolt
2. Eccentric adjuster
3. C-spanner

To adjust the drive chain free movement:

- Loosen the adjuster clamp bolt.
- Using the C-spanner supplied in the tool kit, turn the rear hub/eccentric adjuster (clockwise to loosen, anti-clockwise to tighten) until the drive chain is correctly adjusted.
- Tighten the clamp bolt to **55 Nm**.
- Repeat the drive chain adjustment check. Readjust if necessary.

Warning

Operation of the motorcycle with an insecure rear hub/eccentric adjuster clamp bolt may result in impaired stability and handling of the motorcycle. This impaired stability and handling may lead to loss of control or an accident.

- Check the rear brake effectiveness. Rectify if necessary.

Maintenance

Warning

It is dangerous to operate the motorcycle with defective brakes; you must have your authorised Triumph dealer take remedial action before you attempt to ride the motorcycle again.

Failure to take remedial action may reduce braking efficiency leading to loss of control or an accident.

Chain and Sprocket Wear Inspection

Warning

Never neglect chain maintenance and always have chains installed by an authorised Triumph dealer.

Use a genuine Triumph supplied chain as specified in the Triumph parts catalogue.

The use of non-approved chains may result in a broken chain or may cause the chain to jump off the sprockets leading to loss of motorcycle control or an accident.

Caution

If the sprockets are found to be worn, always replace the sprockets and drive chain together.

Replacing worn sprockets without also replacing the chain will lead to premature wear of the new sprockets.

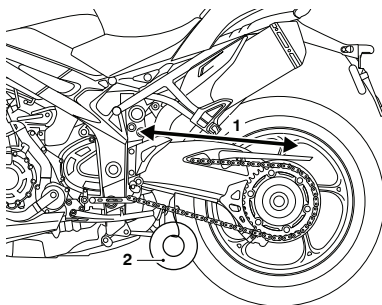

1. Measure across 20 links
2. Weight

To inspect the drive chain and sprocket wear:

- Stretch the drive chain taut by hanging a 10 - 20 kg weight on the drive chain.
- Measure the length of 20 links on the straight part of the drive chain from the pin centre of the 1st pin to the pin centre of the 21st pin. Since the drive chain may wear unevenly, take measurements in several places.
- If the length exceeds the maximum service limit of 321 mm, the drive chain must be replaced.
- Rotate the rear wheel and inspect the drive chain for damaged rollers, and loose pins and links.
- Also inspect the sprockets for unevenly or excessively worn or damaged teeth.

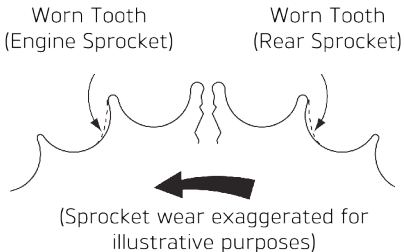

ccol

Illustration shows wear on sprockets mounted on the left hand side of the motorcycle. For sprockets mounted on the right hand side of the motorcycle, the wear is on the opposite side of the tooth.

If there is any irregularity, have the drive chain and/or the sprockets replaced by an authorised Triumph dealer.

Brakes

Brake Wear Inspection

Warning

If fitting new proprietary brand brake pads, check that the carrier plate of the brake pad is at least 4.5 mm thick.

Fitting brake pads with the carrier plate less than 4.5 mm thick may result in brake failure due to the possible loss of the brake pad as it wears.

Brake pads must be inspected in accordance with scheduled maintenance requirements and replaced if worn to, or beyond the minimum service thickness.

If the lining thickness of any pad is less than, 1.0 mm (0.04 in) (front) or 1.5 mm (0.06 in) (rear), replace all the pads on the wheel.

Maintenance

Brake pads for this model supplied by Triumph will have the carrier plate at least 4.5 mm thick. Always have replacement brake pads supplied and fitted by your Triumph dealer.

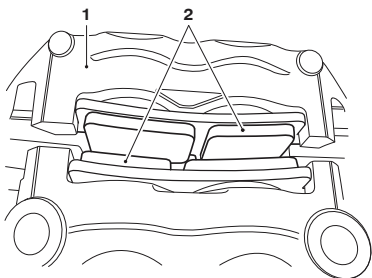

1. Brake caliper, Speed Triple S shown
2. Brake pads

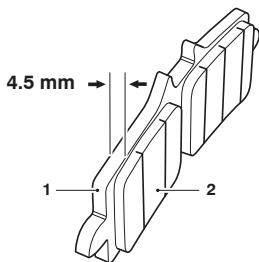

1. Carrier plate, Speed Triple S shown
2. Brake pad

Breaking-in New Brake Pads and Discs

Warning

Brake pads must always be replaced as a wheel set. At the front, where two calipers are fitted on the same wheel, replace all the brake pads in both calipers.

Replacing individual pads will reduce braking efficiency and may cause an accident.

After replacement brake pads have been fitted, ride with extreme caution until the new pads have 'broken in'.

New brake discs and pads require a period of careful breaking-in that will optimise the performance and longevity of the discs and pads. The recommended distance for breaking-in new pads and discs is 200 miles (300 km).

During this period, avoid extreme braking, ride with caution and allow for greater braking distances.

Brake Pad Wear Compensation

Warning

If the brake lever or pedal feels soft when it is applied, or if the lever/pedal travel becomes excessive, there may be air in the brake pipes and hoses or the brakes may be defective.

It is dangerous to operate the motorcycle under such conditions and your authorised Triumph dealer must rectify the fault before riding.

Riding with defective brakes may lead to loss of motorcycle control and an accident.

Disc and brake pad wear is automatically compensated for and has no effect on the brake lever or pedal action. There are no parts that require adjustment on the front and rear brakes.

Disc Brake Fluid

Warning

Brake fluid is hygroscopic which means it will absorb moisture from the air.

Any absorbed moisture will greatly reduce the boiling point of the brake fluid causing a reduction in braking efficiency.

Because of this, always replace brake fluid in accordance with scheduled maintenance requirements.

Always use new brake fluid from a sealed container and never use fluid from an unsealed container or from one which has been previously opened.

Do not mix different brands or grades of brake fluid.

Check for fluid leakage around brake fittings, seals and joints and also check the brake hoses for splits, deterioration and damage.

Always rectify any faults before riding.

Failure to observe and act upon any of these items may cause a dangerous riding condition leading to loss of control and an accident.

Warning

If the ABS is not functioning, the brake system will continue to function as a non-ABS equipped brake system. In this situation, braking too hard will cause the wheels to lock resulting in loss of control and an accident.

Reduce speed and do not continue to ride for longer than is necessary with the indicator light illuminated. Contact an authorised Triumph dealer as soon as possible to have the fault checked and rectified.

Inspect the level of brake fluid in both reservoirs and change the brake fluid in accordance with scheduled maintenance requirements. Use only DOT 4 fluid as recommended in the Specification section. The brake fluid must also be changed if it becomes, or is suspected of having become contaminated with moisture or any other contaminants.

Note:

- **A special tool is required to bleed the ABS braking system. Contact your authorised Triumph dealer when the brake fluid needs renewing or the hydraulic system requires maintenance.**

Brake Fluid Level Inspection and Adjustment

Warning

If there has been an appreciable drop in the level of the fluid in either fluid reservoir, consult your authorised Triumph dealer for advice before riding.

Riding with depleted brake fluid levels, or with a brake fluid leak is dangerous and will cause reduced brake performance potentially leading to loss of motorcycle control and an accident.

Front Brake

The brake fluid level in the reservoirs must be kept between the MIN and MAX level lines (reservoir held horizontal).

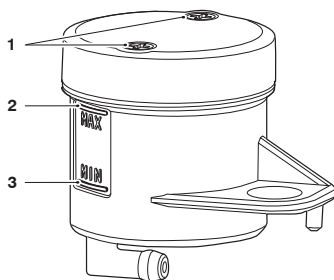

1. Cap retaining screws
2. MAX level line
3. MIN level line

To check and adjust the front brake fluid level:

- Remove the cap retaining screws and remove the reservoir cover.
- Remove the diaphragm seal, noting the location.
- Fill the reservoir to the upper level line using new DOT 4 brake fluid from a sealed container.
- Refit the reservoir cover making sure that the diaphragm seal is correctly fitted.
- Tighten the cap retaining screws to **1 Nm**.

Rear Brake

The brake fluid level in the reservoirs must be kept between the LOWER and UPPER level lines (reservoir held horizontal).

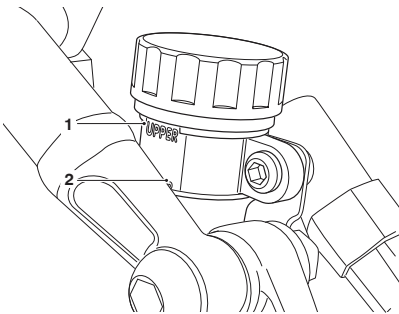

1. UPPER level line
2. LOWER level line

To check and adjust the rear brake fluid level:

- Remove the reservoir cover.
- Fill the reservoir to the UPPER level line using new DOT 4 brake fluid from a sealed container.
- Refit the reservoir cover making sure that the diaphragm seal is correctly fitted.
- Tighten the cap to close.

Brake Light Switches

Warning

Riding the motorcycle with defective brake lights is illegal and dangerous.

An accident causing injury to the rider and other road users may result from use of a motorcycle with defective brake lights.

The brake light is activated independently by either the front or rear brake. If, with the ignition in the ON position, the brake light does not work when the front brake lever is pulled or the rear brake pedal is pressed, have your authorised Triumph dealer investigate and rectify the fault.

Maintenance

Mirrors

Warning

Operation of the motorcycle with incorrectly adjusted mirrors is dangerous.

Operation of the motorcycle with incorrectly adjusted mirrors will result in loss of vision to the rear of the motorcycle. It is dangerous to ride a motorcycle without sufficient rearward vision.

Always adjust the mirrors to provide sufficient rearward vision before riding the motorcycle.

Warning

Never attempt to clean or adjust mirrors while riding the motorcycle. Removal of the rider's hands from the handlebars while riding the motorcycle will diminish the ability of the rider to maintain control of the motorcycle.

Attempting to clean or adjust mirrors while riding the motorcycle may result in loss of control of the motorcycle and an accident.

Only attempt to clean or adjust the mirrors while stationary.

Warning

Incorrect adjustment of the bar end mirrors may cause the mirror arm to contact the fuel tank, brake or clutch levers or other parts of the motorcycle.

This will restrict brake or clutch lever operation or restrict steering movement, resulting in loss of motorcycle control and an accident.

Adjust the mirrors as required to make sure they do not contact any part of the motorcycle. After adjustment, move the handlebar to the left and right full lock while checking that the mirrors do not contact the fuel tank, brake or clutch levers or other parts of the motorcycle.

Caution

Incorrect adjustment of the bar end mirrors may cause the mirror arm to contact the fuel tank, brake or clutch levers or other parts of the motorcycle.

This will result in damage to the fuel tank, brake or clutch levers or other parts of the motorcycle.

Adjust the mirrors as required to make sure they do not contact any part of the motorcycle. After adjustment, move the handlebar to the left and right full lock while checking that the mirrors do not contact the fuel tank, brake or clutch levers or other parts of the motorcycle.

The bar end mirrors will be set by your authorised Triumph dealer and will not normally require any adjustment. Should adjustment be necessary, do not rotate the mirror beyond 75°, measured from the vertical section of the mirror arm.

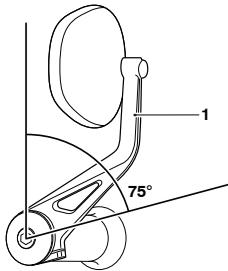

1. Mirror arm vertical section

Steering/Wheel Bearings

Warning

To prevent risk of injury from the motorcycle falling during the inspection, make sure that the motorcycle is stabilised and secured on a suitable support.

Do not exert extreme force against each wheel or rock each wheel vigorously as this may cause the motorcycle to become unstable and cause injury by falling from its support.

Make sure that the position of the support block will not cause damage to the motorcycle.

Steering Inspection

Warning

Riding the motorcycle with incorrectly adjusted or defective steering (head-stock) bearings is dangerous and may cause loss of motorcycle control and an accident.

Maintenance

Note:

- Always inspect the wheel bearings at the same time as the steering bearings.

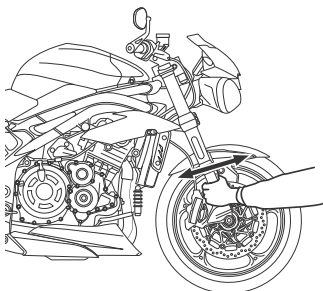

Inspecting the Steering for Free Play

To inspect the steering:

- Lubricate and inspect the condition of the steering (headstock) bearings in accordance with scheduled maintenance requirements.
- Position the motorcycle on level ground, in an upright position.
- Raise the front wheel above the ground and support the motorcycle.
- Standing at the front of the motorcycle, hold the lower end of the front forks and try to move them forwards and backwards.
- If any free play can be detected in the steering (headstock) bearings, ask your authorised Triumph dealer to inspect and rectify any faults before riding.
- Remove the support and place the motorcycle on the side stand.

Wheel Bearings Inspection

Warning

Operation with worn or damaged front or rear wheel bearings is dangerous and may cause impaired handling and instability leading to an accident. If in doubt, have the motorcycle inspected by an authorised Triumph dealer before riding.

If the wheel bearings in the front or rear wheel allow play in the wheel hub, are noisy, or if the wheel does not turn smoothly, have your authorised Triumph dealer inspect the wheel bearings.

The wheel bearings must be inspected at the intervals specified in the scheduled maintenance chart.

To inspect the wheel bearings:

- Position the motorcycle on level ground, in an upright position.
- Raise the front wheel above the ground and support the motorcycle.
- Standing at the side of the motorcycle, gently rock the top of the front wheel from side to side.
- If any free play can be detected, ask your authorised Triumph dealer to inspect and rectify any faults before riding.
- Reposition the lifting device and repeat the procedure for the rear wheel.
- Remove the support and place the motorcycle on the side stand.

Suspension

Front Fork Inspection

 **Warning**

Riding the motorcycle with defective or damaged suspension is dangerous and may lead to loss of control and an accident.

 **Warning**

Never attempt to dismantle any part of the suspension units, as all units contain pressurised oil. Skin and eye damage can result from contact with the pressurised oil.

Note:

- **The suspension movement will be affected by adjustment settings.**

Examine each fork for any sign of damage, scratching of the slider surface, or for oil leaks.

If any damage or leakage is found, consult an authorised Triumph dealer.

To check that the forks operate smoothly:

- Position the motorcycle on level ground.
- While holding the handlebars and applying the front brake, pump the forks up and down several times.
- If roughness or excessive stiffness is detected, consult your authorised Triumph dealer.

Maintenance

Suspension Setting Chart - Speed Triple S

Warning

Make sure that the correct balance between front and rear suspension is maintained.

Suspension imbalance could significantly change handling characteristics leading to loss of control and an accident.

Refer to the chart below for further information or consult your dealer.

Warning

Make sure that the adjusters are set to the same setting on both forks.

Settings which vary from left to right could significantly change handling characteristics leading to loss of control and an accident.

The standard suspension settings provide a comfortable ride and good handling characteristics for general, solo riding. The chart shows suggested settings for the front and rear suspension.

LOADING		FRONT			REAR	
		Spring Pre-Load ¹	Rebound Damping ¹	Compression Damping ¹	Rebound Damping ¹	Compression Damping ¹
Solo Riding	Road	8	2.5	2	2.5	2
	Comfort	8	2.75 ²	3 ²	2.75 ²	3 ²
	Track	8	1	0.5	0.75	0.5
	Sport	8	1.5	1.5	1.5	1.5
Rider and Passenger		8	1.5	1.5	1	1

¹ Number of adjuster turns anticlockwise from the fully clockwise position.

² Number of maximum adjuster turns unless already fully screwed out.

Note:

- The Speed Triple S motorcycle is delivered from the factory with the suspension set at the Road riding settings, as shown in the relevant suspension chart.

Note:

- These charts are only a guide. Setting requirements may vary for rider weight and personal preferences. See the following pages for information regarding suspension adjustment.

Suspension Setting Chart - Speed Triple RS

Warning

Make sure that the correct balance between front and rear suspension is maintained.

Suspension imbalance could significantly change handling characteristics leading to loss of control and an accident.

Refer to the chart below for further information or consult your dealer.

Warning

Make sure that the adjusters are set to the same setting on both forks.

Settings which vary from left to right could significantly change handling characteristics leading to loss of control and an accident.

The standard suspension settings provide a comfortable ride and good handling characteristics for general, solo riding. The chart shows suggested settings for the front and rear suspension.

LOADING		FRONT			REAR	
		Spring Pre-Load ¹	Rebound Damping ²	Compression Damping ²	Rebound Damping ²	Compression Damping ²
Solo Riding	Road	7	16	19	16	19
	Comfort	7	16	26	16	fully anti-clockwise
	Track	7	9	9	7	7
	Sport	7	11	16	11	18
Rider and Passenger		7	10	12	8	15

¹ Number of adjuster turns clockwise from the fully anticlockwise position.

² Number of clicks anticlockwise from the fully clockwise position noting that the first stop (click) is counted as one.

Note:

- The Speed Triple RS motorcycle is delivered from the factory with the suspension set at the Road riding settings, as shown in the relevant suspension chart.

Note:

- These charts are only a guide. Setting requirements may vary for rider weight and personal preferences. See the following pages for information regarding suspension adjustment.

Maintenance

Front Suspension Adjustment

Spring Preload Adjustment - All Models

The spring preload adjusters are located at the top of each fork.

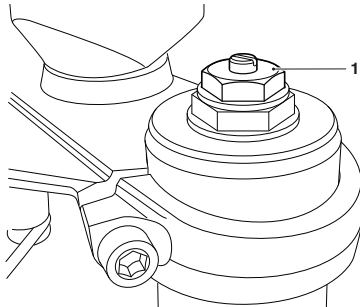

1. Speed Triple S spring preload adjuster

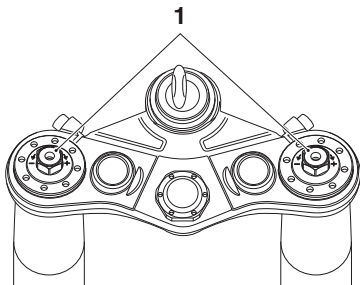

1. Speed Triple RS spring preload adjusters

To change the spring preload:

- Rotate the adjuster clockwise to increase preload, or anticlockwise to decrease preload.
- Always count the number of clockwise turns from the fully anticlockwise position and set both forks to the same settings.

Note:

- The Speed Triple S is delivered from the factory with the spring preload set at 7.5 clockwise turns from the fully anticlockwise position.
- The Speed Triple RS is delivered from the factory with the spring preload set at 8.5 clockwise turns from the fully anticlockwise position.

Rebound Damping Adjustment - Speed Triple S

The rebound damping adjuster is located at the top of each fork.

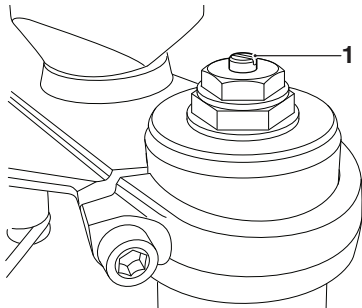

1. Rebound damping adjuster

To change the rebound damping force:

- Rotate the slotted adjuster clockwise to increase, or anticlockwise to decrease.
- Always count the number of anticlockwise turns from the fully clockwise position and set both forks to the same settings.

Note:

- **The motorcycle is delivered from the factory with the rebound set at 2.5 anticlockwise turns from the fully clockwise position.**

Rebound Damping Adjustment - Speed Triple RS

The rebound damping adjuster is located at the top of the right hand fork.

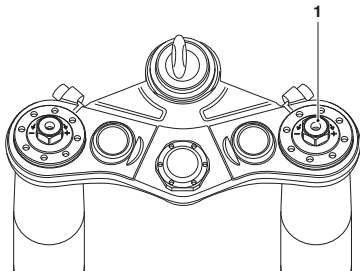

1. Rebound damping adjuster

To change the rebound damping force:

- Rotate the adjuster clockwise to increase, or anticlockwise to decrease using a 3 mm Allen key.
- Always count the number of clicks from the fully clockwise position noting that the first stop (click position) is counted as zero.

Note:

- **The motorcycle is delivered from the factory with the rebound set at 16 clicks from the fully clockwise position.**

Compression Damping Adjustment - Speed Triple S

The compression damping adjuster is located near the bottom of both forks, adjacent to the wheel spindle.

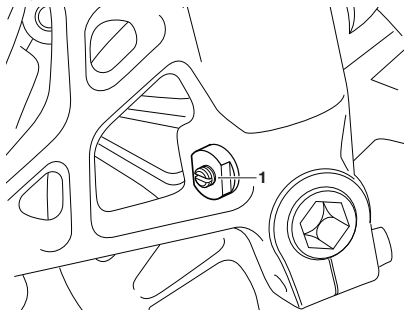

1. Compression damping adjuster

To change the compression damping force:

- Rotate the slotted adjuster clockwise to increase, or anticlockwise to decrease.
- Always count the number of anticlockwise turns from the fully clockwise position and set both forks to the same settings.

Note:

- **The motorcycle is delivered from the factory with the compression damping set at 2 anticlockwise turns from the fully clockwise position.**

Maintenance

Compression Damping Adjustment - Speed Triple RS

The compression damping adjuster is located at the top of the left hand fork.

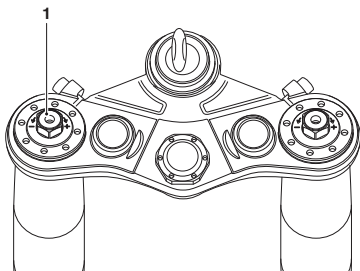

1. Compression damping adjuster

To change the compression damping force:

- Rotate the adjuster clockwise to increase, or anticlockwise to decrease using a 3 mm Allen key.
- Always count the number of clicks from the fully clockwise position noting that the first stop (click position) is counted as zero.

Note:

- The motorcycle is delivered from the factory with the compression damping set at 19 clicks from the fully clockwise position.

Rear Suspension Adjustment

The rear suspension unit is adjustable for both rebound and compression damping.

Rebound Damping Adjustment - Speed Triple S

The rebound damping adjuster is located at the bottom of the rear suspension unit on the left hand side of the motorcycle.

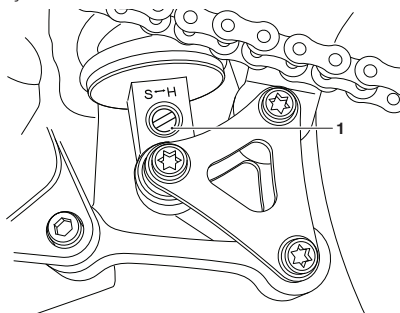

1. Rebound damping adjuster

To adjust the rebound damping setting:

- Rotate the adjuster clockwise to increase rebound damping and anticlockwise to decrease.
- Always count the number of anticlockwise turns from the fully clockwise position.

Note:

- The motorcycle is delivered from the factory with the rebound adjuster set at 2.5 anticlockwise turns from the fully clockwise position.

Rebound Damping Adjustment - Speed Triple RS

The rebound damping adjuster is accessible from the left hand side of the motorcycle. It is coloured black and is situated close to the rear suspension reservoir.

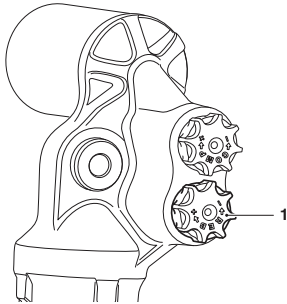

1. Rebound damping adjuster

To adjust the rebound damping setting:

- Rotate the adjuster clockwise to increase rebound damping and anticlockwise to decrease.
- Always count the number of clicks anticlockwise from the fully clockwise position noting that the first stop (click position) is counted as zero.

Note:

- The motorcycle is delivered from the factory with the rebound adjuster set at 16 clicks from the fully clockwise position.

Compression Damping Adjustment - Speed Triple S

The compression damping adjuster is situated below the rear suspension unit reservoir.

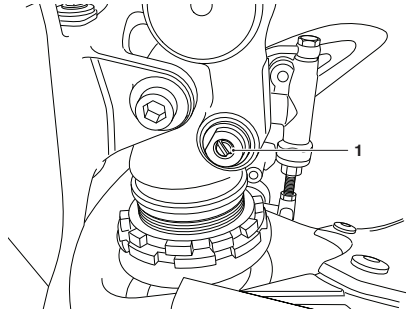

1. Compression damping adjuster

To adjust the compression damping setting:

- Rotate the slotted adjuster clockwise to increase, or anticlockwise to decrease.
- Always count the number of anticlockwise turns from the fully clockwise position.

Note:

- The motorcycle is delivered from the factory with the compression damping set at 2 anticlockwise turns from the fully clockwise position.

Maintenance

Compression Damping Adjuster - Speed Triple RS

The compression damping adjuster is accessible from the left hand side of the motorcycle. It is coloured gold and is situated close to the rear suspension reservoir.

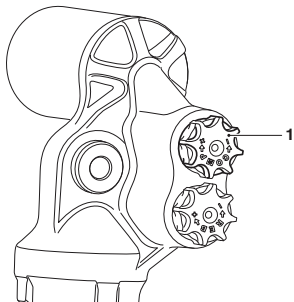

1. Compression damping adjuster

To adjust the rebound damping setting:

- Rotate the adjuster clockwise to increase rebound damping and anticlockwise to decrease.
- Always count the number of clicks anticlockwise from the fully clockwise position noting that the first stop (click position) is counted as zero.

Note:

- The motorcycle is delivered from the factory with the rebound adjuster set at 19 clicks from the fully clockwise position.

Spring Preload - All Models



Warning

The rear suspension unit spring preload is not rider adjustable.

Any attempt to adjust the spring preload could result in a dangerous riding condition leading to loss of control and an accident.

Tyres



cboa

This motorcycle is equipped with tubeless tyres, valves and wheel rims. Use only tyres marked 'TUBELESS' and tubeless valves on rims marked 'TUBELESS'.

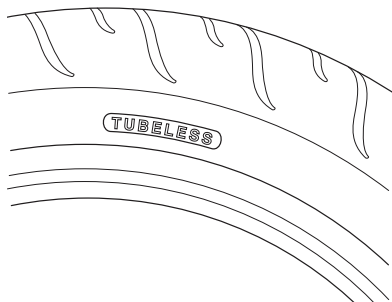

Typical Tyre Marking

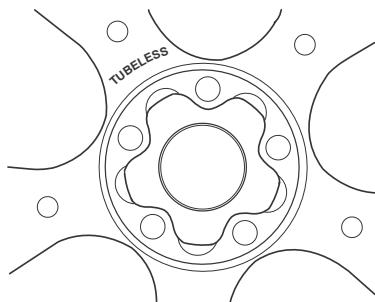

Wheel Marking

Tyre Inflation Pressures

Warning

Incorrect tyre inflation will cause abnormal tread wear and instability problems that may lead to loss of control and an accident.

Underinflation may result in the tyre slipping on, or coming off the rim. Overinflation will cause instability and accelerated tread wear.

Both conditions are dangerous as they may cause loss of control leading to an accident.

Correct inflation pressure will provide maximum stability, rider comfort and tyre life. Always check tyre pressures before riding when the tyres are cold. Check tyre pressures daily and adjust if necessary. See the Specification section for details of the correct inflation pressures.

Tyre Pressure Monitoring System (if fitted)

Caution

An adhesive label is fitted to the wheel rim to indicate the position of the tyre pressure sensor.

Care must be taken when replacing the tyres to prevent any damage to the tyre pressure sensors.

Always have your tyres fitted by your authorised Triumph dealer and inform them that tyre pressure sensors are fitted to the wheels.

Caution

Do not use anti puncture fluid or any other item likely to obstruct air flow to the TPMS sensor's orifices. Any blockage to the air pressure orifice of the TPMS sensor during operation will cause the sensor to become blocked, causing irreparable damage to the TPMS sensor assembly.

Damage caused by the use of anti puncture fluid or incorrect maintenance is not considered a manufacturing defect and will not be covered under warranty.

Always have your tyres fitted by your authorised Triumph dealer and inform them that tyre pressure sensors are fitted to the wheels.

The tyre pressures shown on your instruments indicate the actual tyre pressure at the time of selecting the display. This may differ from the inflation pressure set when the tyres are cold because tyres become warmer during riding, causing the air in the tyre to expand and increase the inflation pressure. The cold inflation pressures specified by Triumph take account of this.

Only adjust tyre pressures when the tyres are cold using an accurate pressure gauge. Do not use the tyre pressure display on the instruments.

Tyre Wear

As the tyre tread wears down, the tyre becomes more susceptible to punctures and failure. It is estimated that 90% of all tyre problems occur during the last 10% of tread life (90% worn). It is recommended that tyres are changed before they are worn to their minimum tread depth.

Minimum Recommended Tread Depth

Warning

Operation with excessively worn tyres is hazardous and will adversely affect traction, stability and handling which may lead to loss of control and an accident.

When tubeless tyres become punctured, leakage is often very slow. Always inspect tyres very closely for punctures. Check the tyres for cuts, embedded nails or other sharp objects. Operation with punctured or damaged tyres will adversely affect motorcycle stability and handling which may lead to loss of control or an accident.

Check the rims for dents or deformation. Operation with damaged or defective wheels or tyres is dangerous and loss of motorcycle control or an accident could result.

Always consult your authorised Triumph dealer for tyre replacement, or for a safety inspection of the tyres.

Warning

Only operate this Triumph motorcycle at high speed in closed-course on-road competition or on closed-course race-tracks. High speed operation should only then be attempted by riders who have been instructed in the techniques necessary for high speed riding and are familiar with the motorcycle's characteristics in all conditions.

High speed operation in any other circumstances is dangerous and will lead to loss of motorcycle control and an accident.

Warning

This motorcycle must not be operated above the legal road speed limit except in authorised closed-course conditions.

In accordance with the periodic maintenance chart, measure the depth of the tread with a depth gauge, and replace any tyre that has worn to, or beyond the minimum allowable tread depth specified in the table below:

Under 130 km/h (80 mph)	2 mm (0.08 in)
Over 130 km/h (80 mph)	Rear 3 mm (0.12 in) Front 2 mm (0.08 in)

Tyre Replacement

All Triumph motorcycles are carefully and extensively tested in a range of riding conditions to ensure that the most effective tyre combinations are approved for use on each model. It is essential that approved tyres fitted in approved combinations, are used when purchasing replacement items. The use of non-approved tyres, or approved tyres in non-approved combinations, may lead to motorcycle instability, loss of control and an accident.

A list of approved tyres specific to your motorcycle are available from your authorised Triumph dealer, or on the Internet at www.triumph.co.uk. Always have tyres fitted and balanced by your authorised Triumph dealer who has the necessary training and skills to ensure safe, effective fitment.

Different wheel speeds, caused by non-approved tyres, can affect the function of the ABS computer.

Warning

The ABS operates by comparing the relative speed of the front and rear wheels. Use of non-recommended tyres can affect wheel speed and cause the ABS function not to operate, potentially leading to loss of control and an accident in conditions where the ABS would normally function.

Maintenance

Warning

If a tyre sustains a puncture, the tyre must be replaced. Failure to replace a punctured tyre, or operation with a repaired tyre can lead to instability, loss of motorcycle control or an accident.

Warning

Do not install tube-type tyres on tubeless rims. The bead will not seat and the tyres could slip on the rims, causing rapid tyre deflation that may result in a loss of vehicle control and an accident. Never install an inner tube inside a tubeless tyre without the appropriate marking. This will cause friction inside the tyre and the resulting heat build-up may cause the tube to burst resulting in rapid tyre deflation, loss of vehicle control and an accident.

Warning

If tyre damage is suspected, such as after striking the kerb, ask your authorised Triumph dealer to inspect the tyre both internally and externally. Remember, tyre damage may not always be visible from the outside. Operation of the motorcycle with damaged tyres could lead to loss of control and an accident.

Warning

Tyres that have been used on a rolling road dynamometer may become damaged. In some cases, the damage may not be visible on the external surface of the tyre.

Tyres must be replaced after such use as continued use of a damaged tyre may lead to instability, loss of motorcycle control and an accident.

Warning

Accurate wheel balance is necessary for safe, stable handling of the motorcycle. Do not remove or change any wheel balance weights. Incorrect wheel balance may cause instability leading to loss of control and an accident.

When wheel balancing is required, such as after tyre replacement, see your authorised Triumph dealer.

Only use self-adhesive weights. Clip on weights may damage the wheel or tyre resulting in tyre deflation, loss of motorcycle control and an accident.

Warning

When replacement tyres are required, consult your authorised Triumph dealer who will arrange for the tyres to be selected, in a correct combination, from the approved list and fitted according to the tyre manufacturer's instructions.

When tyres are replaced, allow time for the tyres to seat to the rim (approximately 24 hours). During this seating period, ride cautiously as an incorrectly seated tyre could cause instability, loss of motorcycle control and an accident.

Initially, the new tyres will not produce the same handling characteristics as the worn tyres and the rider must allow adequate riding distance (approximately 100 miles (160 km)) to become accustomed to the new handling characteristics.

24 hours after fitting, the tyre pressures must be checked and adjusted, and the tyres examined for correct seating. Rectification must be carried out as necessary. The same checks and adjustments must also be carried out when 100 miles (160 km) have been travelled after fitting.

Use of a motorcycle with incorrectly seated tyres, incorrectly adjusted tyre pressures, or when not accustomed to its handling characteristics may lead to loss of motorcycle control and an accident.

Battery

Warning

Under some circumstances, the battery can give off explosive gases; keep sparks, flames and cigarettes away. Provide adequate ventilation when charging or using the battery in an enclosed space.

The battery contains sulphuric acid (battery acid). Contact with skin or eyes may cause severe burns. Wear protective clothing and a face shield.

If battery acid gets on your skin, flush with water immediately.

If battery acid gets in your eyes, flush with water for at least 15 minutes and SEEK MEDICAL ATTENTION IMMEDIATELY.

If battery acid is swallowed, drink large quantities of water and SEEK MEDICAL ATTENTION IMMEDIATELY.

KEEP BATTERY ACID OUT OF THE REACH OF CHILDREN.

Warning

The battery contains harmful materials. Always keep children away from the battery whether or not it is fitted in the motorcycle.

Do not attach jump leads to the battery, touch the battery cables together or reverse the polarity of the cables as any of these actions may cause a spark which would ignite battery gases causing a risk of personal injury.

Maintenance

Battery Removal



Make sure that the battery terminals do not touch the motorcycle frame as this may cause a short circuit or spark, which would ignite battery gases causing a risk of personal injury.

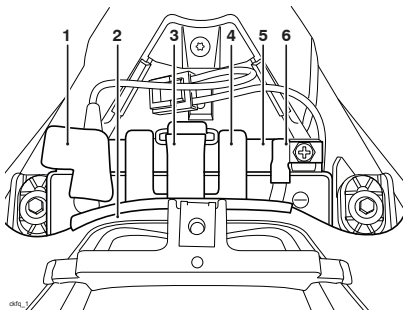

1. **Positive (red) terminal**
2. **Fuel tank**
3. **Battery strap**
4. **Battery bracket**
5. **Battery**
6. **Negative (black) terminal**

To remove the battery:

- Raise and support the fuel tank (see page 105).
- Remove the battery strap.
- Remove the battery bracket.
- Disconnect the battery leads, negative (black) lead first.
- Take the battery out of the case.

Battery Disposal

Should the battery ever require replacement, the original battery must be handed to a recycling agent who will make sure that the dangerous substances from which the battery is manufactured do not pollute the environment.

Battery Maintenance



Battery acid is corrosive and poisonous and will cause damage to unprotected skin. Never swallow battery acid or allow it to come into contact with the skin. To prevent injury, always wear eye and skin protection when handling the battery.

Clean the battery using a clean, dry cloth. Make sure that the cable connections are clean.

The battery is a sealed type and does not require any maintenance other than checking the voltage and routine recharging when required, such as during storage (see the following paragraphs).

It is not possible to adjust the battery acid level in the battery; the sealing strip must not be removed.

Battery Discharge



The charge level in the battery must be maintained to maximise battery life.

Failure to maintain the battery charge level could cause serious internal damage to the battery.

Under normal conditions, the motorcycle charging system will keep the battery fully charged. However, if the motorcycle is unused, the battery will gradually discharge due to a normal process called self discharge; the clock, Engine Control Module (ECM) memory, high ambient temperatures, or the addition of electrical security systems or other electrical accessories will all increase this rate of battery discharge. Disconnecting the battery from the motorcycle during storage will reduce the rate of discharge.

Battery Discharge During Storage and Infrequent Use of the Motorcycle

During storage or infrequent use of the motorcycle, inspect the battery voltage weekly using a digital multimeter. Follow the manufacturer's instructions supplied with the meter.

Should the battery voltage fall below 12.7 Volts, the battery should be charged.

Allowing a battery to discharge or leaving it discharged for even a short period of time causes sulphation of the lead plates. Sulphation is a normal part of the chemical reaction inside the battery,

however over time the sulphate can crystallise on the plates making recovery difficult or impossible. This permanent damage is not covered by the motorcycle warranty, as it is not due to a manufacturing defect.

Keeping the battery fully charged reduces the likelihood of it freezing in cold conditions. Allowing a battery to freeze will cause serious internal damage to the battery.

Battery Charging



The battery gives off explosive gases; keep sparks, flames and cigarettes away. Provide adequate ventilation when charging or using the battery in an enclosed space.

The battery contains sulphuric acid (battery acid). Contact with skin or eyes may cause severe burns. Wear protective clothing and a face shield.

If battery acid gets on your skin, flush with water immediately.

If battery acid gets in your eyes, flush with water for at least 15 minutes and SEEK MEDICAL ATTENTION IMMEDIATELY.

If battery acid is swallowed, drink large quantities of water and SEEK MEDICAL ATTENTION IMMEDIATELY.

KEEP BATTERY ACID OUT OF THE REACH OF CHILDREN.

Maintenance

Caution

Do not use an automotive quick charger as it may overcharge and damage the battery.

For help with selecting a battery charger, checking the battery voltage or battery charging, contact your local authorised Triumph dealer.

Should the battery voltage fall below 12.7 Volts, the battery should be charged using a Triumph approved battery charger. Always remove the battery from the motorcycle and follow the instructions supplied with the battery charger.

For extended periods of storage (beyond two weeks) the battery should be removed from the motorcycle and kept charged using a Triumph approved maintenance charger.

Similarly, should the battery charge fall to a level where it will not start the motorcycle, remove the battery from the motorcycle before charging.

To install the battery:

- Place the battery in the battery case.
- Reconnect the battery, positive (red) lead first.
- Apply a light coat of grease to the terminals to prevent corrosion.
- Cover the positive terminal with the protective cap.
- Refit the battery bracket.
- Refit the battery strap.
- Lower and secure the fuel tank (see page **106**).

Battery Installation

Warning

Make sure that the battery terminals do not touch the motorcycle frame as this may cause a short circuit or spark, which would ignite battery gases causing a risk of personal injury.

Fuse Boxes



Warning

Always replace blown fuses with new ones of the correct rating (as specified on the fuse box cover) and never use a fuse of higher rating.

Use of an incorrect fuse could lead to an electrical problem, resulting in motorcycle damage, loss of motorcycle control and an accident.

The two fuse boxes are located under the seat.

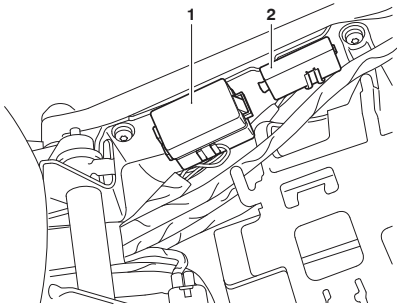

1. Front fuse box
2. Rear fuse box

Fuse Identification

A blown fuse is indicated when all of the systems protected by that fuse become inoperative. When checking for a blown fuse, use the tables to establish which fuse has blown.

The fuse identification numbers listed in the tables correspond with those printed on the fuse box cover, as shown. Spare fuses are located at right angles to the main fuses and should be replaced if used.

Front Fuse Box

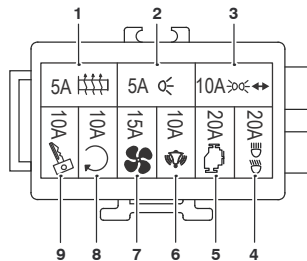

Fuse Box

Position	Circuits Protected	Rating (Amps)
1	Heated Grips (if fitted)	5
2	Rear Light, License Plate Light	5
3	Horn, Direction Indicators, Daytime Running Lights (DRL) (if fitted) and Instruments	10
4	Dipped and High Beam Headlights	20
5	Engine ECM	20
6	Alarm, Electronic Steering Lock (Speed Triple RS Only)	10

Maintenance

7	Cooling Fan	15
8	Fuel Pump	10
9	Ignition Switch	10

Rear Fuse Box

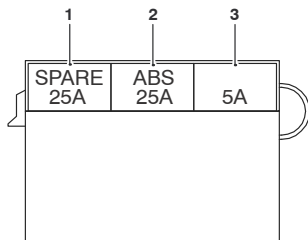

Rear Fuse Box

Position	Circuits Protected	Rating (Amps)
1	Spare	25
2	ABS	25
3	Keyless Control Unit (KCU)	5

Table 1: Speed Triple RS

Position	Circuits Protected	Rating (Amps)
1	Spare	25
2	ABS	25
3	Spare	5

Table 2: Speed Triple S

Main Fuse

The 30 Amp main fuse is located in front of the battery. To allow access to this fuse, the front panel on the fuel tank must be removed.

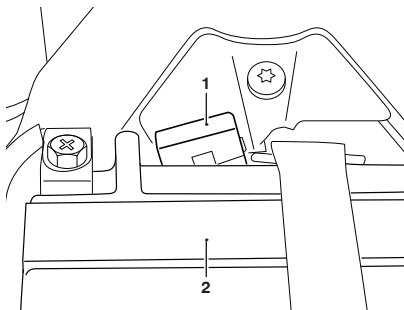

1. Main fuse
2. Battery

Headlights

Warning

Adjust road speed to suit the visibility and weather conditions in which the motorcycle is being operated.

Make sure that the beams are adjusted to illuminate the road surface sufficiently far ahead without dazzling oncoming traffic. An incorrectly adjusted headlight may impair visibility causing an accident.

Warning

Never attempt to adjust a headlamp beam when the motorcycle is in motion.

Any attempt to adjust a headlamp beam when the motorcycle is in motion may result in loss of control and an accident.

Caution

If the motorcycle is to be used under closed-course conditions, you may be asked to tape the visible outer surface of the headlight

When taped, the headlight will overheat and distort the outer surface. Therefore, to avoid headlight distortion, always disconnect the headlights when they are taped for use under closed-course conditions.

Caution

Do not cover the headlight or lens with any item likely to obstruct air flow to, or prevent heat escaping from, the headlight lens.

Covering the headlight lens during operation with items of clothing, luggage, adhesive tape, devices intended to alter or adjust the headlight beam or non genuine headlight lens covers will cause the headlight lens to overheat and distort, causing irreparable damage to the headlight assembly.

Damage caused by overheating is not considered a manufacturing defect and will not be covered under warranty.

If the headlight must be covered during use, such as the taping of the headlight lens required during closed-course conditions, the headlight must be disconnected.

Maintenance

Headlight Adjustment - Vertical

The vertical beams of the left and right hand headlights can only be adjusted together. Independent adjustment is not possible.

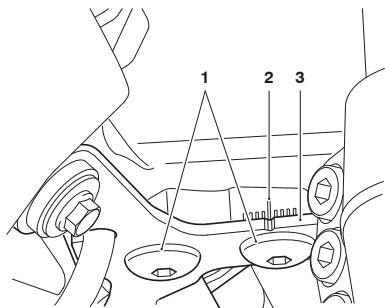

1. Bolts
2. Front subframe alignment marks
3. Headlight bracket

To adjust the vertical headlight beam:

- Switch the headlight dipped beam on.
- Loosen the two bolts securing the headlight bracket to the front subframe sufficiently to allow restricted movement of the headlights.
- Using the headlight bracket mark and the alignment markings on the front subframe, adjust the position of the headlights to give the required beam setting. Each mark on the subframe represents 1°.
- Moving the bracket forwards moves the headlight downwards. Moving the bracket rearwards moves the headlights upwards.
- Tighten the headlight bracket bolts to **7 Nm**.
- Recheck the headlight beam settings.
- Switch the headlights off when the beam settings are satisfactorily set.

Headlight Bulb Replacement

Warning

The bulbs become hot during use. Always allow sufficient time for the bulbs to cool before handling.

Avoid touching the glass part of the bulb. If the glass is touched or gets dirty, clean with alcohol before reuse.

⚠ Caution

The use of non-approved headlight bulbs may result in damage to the headlight lens.

Use a genuine Triumph supplied headlight bulb as specified in the Triumph Parts Catalogue.

Always have replacement headlight bulbs installed by an authorised Triumph dealer.

To replace the headlight bulb:

- Release the three fixings and remove the front panel from the fuel tank.

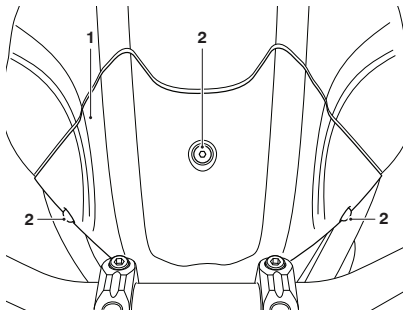

1. Front panel
2. Fixings

- Disconnect the battery, negative (black) lead first.
- Unscrew the headlight bulb cover from the rear of the headlight assembly and remove with the gasket.

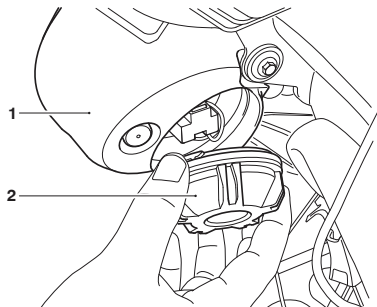

1. Headlight assembly
2. Headlight bulb cover

Maintenance

- Disconnect the multi-pin connector from the headlight bulb.

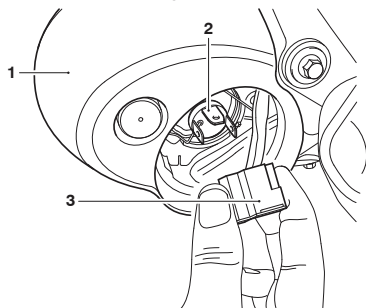

1. Headlight assembly
2. Headlight bulb
3. Multi-pin connector

- Detach the wire retainer from its clip (do not remove the screw) then remove the bulb from the light unit.

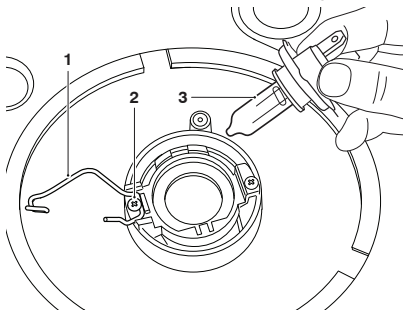

1. Wire retainer
2. Screw
3. Headlight bulb

- Installation is the reverse of the removal procedure.

Warning

Do not reconnect the battery until the assembly process has been completed.

Premature battery reconnection could result in ignition of the battery gases causing risk of injury.

Caution

When reconnecting the battery, connect the positive (red) lead first.

- Reconnect the battery, positive (red) lead first.
- Refit the front panel and tighten the fixings to **2 Nm**.

Daytime Running Lights (DRL) (if fitted)

The daytime running lights are situated within the headlight assembly and are sealed, maintenance free LED units.

Direction Indicator Lights

The direction indicator light units are sealed, maintenance free LED units.

Rear Light

The rear light unit is a sealed, maintenance free LED unit.

License Plate Light

License Plate Bulb Replacement

To replace the license plate bulb:

- Release the three fixings and remove the front panel from the fuel tank.

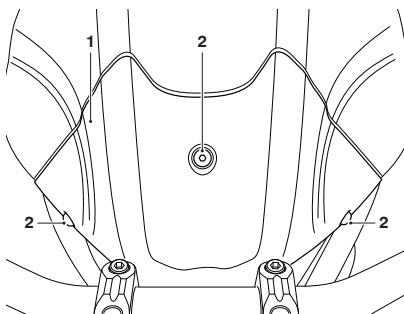

1. Front panel
2. Fixings

- Disconnect the battery, negative (black) lead first.

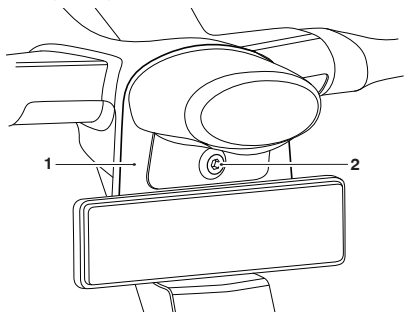

1. License plate bracket
2. Fixing

- Release the fixing and detach the light from the license plate bracket. It is not necessary to disconnect the license plate electrical connectors.

Maintenance

Caution

To avoid cable damage, do not pull the bulb holder using the cables. Pull only on the bulb holder.

- Carefully remove the bulb holder from the back of the license plate light unit. Remove the bulb.

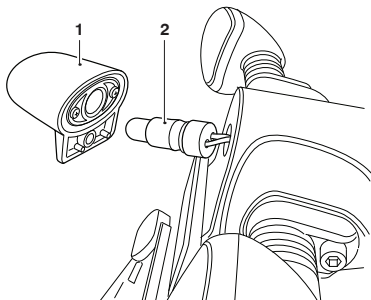

1. License plate light
2. Bulb holder

Installation is the reverse of the removal procedure, noting the following:

- Tighten the lamp fixing to **2 Nm**.
- Reconnect the battery, positive (red) lead first.
- Refit the front panel and tighten the side fixings to **2 Nm**.

CLEANING AND STORAGE

Table of Contents

Cleaning.....	144
Preparation for Washing.....	144
Where to be Careful.....	145
Washing.....	145
After Washing.....	146
Care of Gloss Paintwork.....	146
Care of Matt Paintwork.....	146
Aluminium Items - not Lacquered or Painted.....	147
Cleaning of Chrome and Stainless Steel Items.....	147
Black Chrome.....	148
Cleaning of the Exhaust System.....	148
Seat Care.....	148
Windscreen Cleaning (if fitted).....	149
Care of Leather Products.....	149
Preparation for Storage.....	150
Preparation after Storage.....	151

Cleaning and Storage

Cleaning

Frequent, regular cleaning is an essential part of the maintenance of your motorcycle. If regularly cleaned, the appearance will be preserved for many years.

Cleaning with cold water containing an automotive cleaner is essential at all times but particularly so after exposure to sea breezes, sea water, dusty or muddy roads and in winter when roads are treated for ice and snow.

Do not use household detergent, as the use of such products will lead to premature corrosion.

Although, under the terms of your motorcycle warranty, cover is provided against the corrosion of certain items, the owner is expected to observe this reasonable advice which will safeguard against corrosion and enhance the appearance of the motorcycle.

Preparation for Washing

Before washing, precautions must be taken to keep water off the following places.

Rear opening of the exhausts: Cover with a plastic bag secured with rubber bands.

Clutch and brake levers, switch housings on the handlebar: Cover with plastic bags.

Ignition switch and steering lock: Cover the keyhole with tape.

Remove any items of jewellery such as rings, watches, zips or belt buckles, which may scratch or otherwise damage painted or polished surfaces.

Use separate cleaning sponges or cleaning cloths for washing painted/polished surfaces and chassis areas. Chassis areas (such as wheels and under mudguards) will be exposed to more abrasive road grime and dust, which may then scratch painted or polished surfaces, if the same sponge or cleaning cloths are used.

Where to be Careful

 **Caution**

Do not spray any water at all near the air intake duct. The air intake duct is normally located under the rider's seat, under the fuel tank or near the steering head. Any water sprayed in this area could enter the airbox and engine, causing damage to both items.

 **Caution**

Use of high pressure spray washers is not recommended. When using pressure washers, water may be forced into bearings and other components causing premature wear from corrosion and loss of lubrication.

Avoid spraying water with any great force near the following places:

- Instruments;
- Brake cylinders and brake calipers;
- Under the fuel tank;
- Air intake duct;
- Headstock bearings;
- Wheel bearings.

Note:

- **Use of soaps that are highly alkaline will leave a residue on painted surfaces, and may also cause water spotting. Always use a low alkaline soap to aid the cleaning process.**

Washing

Prepare a mixture of cold water and mild automotive cleaner. Do not use a highly alkaline soap as commonly found at commercial car washes because it leaves a residue.

Wash the motorcycle with a sponge or soft cloth. Do not use abrasive scouring pads or steel wool. They will damage the finish.

Rinse the motorcycle thoroughly with cold water.

Cleaning and Storage

After Washing



Never wax or lubricate the brake discs. Loss of braking power and an accident could result. Clean the disc with a proprietary brand of oil-free brake disc cleaner.

Remove the plastic bags and tape, and clear the air intakes.

Lubricate the pivots, bolts and nuts.

Test the brakes before motorcycle operation.

Use a dry cloth or chamois leather to absorb water residue. Do not allow water to stand on the motorcycle as this will lead to corrosion.

Start the engine and run it for 5 minutes. Make sure that there is adequate ventilation for the exhaust fumes.

Care of Gloss Paintwork

Gloss paintwork should be washed and dried as described above, then protected using a high quality automotive polish. Always follow the manufacturer's instructions and repeat regularly to maintain your motorcycle's appearance.

Care of Matt Paintwork

Matt paintwork requires no greater care than that already recommended for high gloss paintwork.

- Do not use any polish or wax on matt paintwork.
- Do not try and polish out scratches.

Aluminium Items - not Lacquered or Painted

Items such as brake and clutch levers, wheels, engine covers, engine cooling fins, upper and lower yokes and throttle bodies on some models must be correctly cleaned to preserve their appearance. Please contact your dealer if you are unsure which components on your motorcycle are aluminium parts not protected by paint or lacquer, and for guidance on how to clean those items.

Use a proprietary brand of aluminium cleaner which does not contain abrasive or caustic elements.

Clean aluminium items regularly, in particular after use in inclement weather, where the components must be hand washed and dried each time the machine is used.

Warranty claims due to inadequate maintenance will not be allowed.

Cleaning of Chrome and Stainless Steel Items

All chrome and stainless steel parts of your motorcycle must be cleaned regularly to avoid a deterioration of its appearance.

Washing

Wash as previously described.

Drying

Dry the chrome and stainless steel parts as far as possible with a soft cloth or chamois leather.

Protecting



The use of products containing silicone will cause discolouration of the chrome and stainless steel parts and must not be used. Similarly, the use of abrasive cleaners will damage the finish and must not be used.

When the chrome and stainless steel is dry, apply a suitable proprietary chrome cleaner on to the surface, following the manufacturer's instructions.

It is recommended that regular protection be applied to the motorcycle as this will both protect and enhance its appearance.

Cleaning and Storage

Black Chrome

Items such as headlight bowls and mirrors on some models must be correctly cleaned to preserve their appearance. Please contact your dealer if you are unsure which components on your motorcycle are black chrome parts. Maintain the appearance of black chrome items by rubbing a small amount of light oil into the surface.

Cleaning of the Exhaust System

All parts of the exhaust system of your motorcycle must be cleaned regularly to avoid a deterioration of its appearance. These instructions can be applied to chrome, brushed stainless steel and carbon fibre components; matt painted exhaust systems should be cleaned as above, noting the care instructions in the Matt Paintwork section previously.

Note:

- **The exhaust system must be cool before washing to prevent water spotting.**

Washing

Wash as previously described.

Make sure that no soap or water enters the exhausts.

Drying

Dry the exhaust system as far as possible with a soft cloth or chamois leather. Do not run the engine to dry the system or spotting will occur.

Protecting



The use of products containing silicone will cause discolouration of the chrome and must not be used. Similarly, the use of abrasive cleaners will damage the system and must not be used.

When the exhaust system is dry, apply a suitable proprietary motorcycle protection spray onto the surface, following the manufacturer's instructions.

It is recommended that regular protection be applied to the system as this will both protect and enhance the system's appearance.

Seat Care



Use of chemicals or high pressure spray washers is not recommended for cleaning the seat.

Using chemicals or high pressure spray washers may damage the seat cover.

To help maintain its appearance, clean the seat using a sponge or cleaning cloth with soap and water.

Windscreen Cleaning (if fitted)

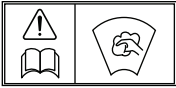

Warning

Never attempt to clean the windscreen while the motorcycle is in motion as releasing the handlebars may cause loss of motorcycle control and an accident.

Operation of the motorcycle with a damaged or scratched windscreen will reduce the rider's forward vision. Any such reduction in forward vision is dangerous and may lead to loss of motorcycle control and an accident.

Caution

Corrosive chemicals such as battery acid will damage the windscreen. Never allow corrosive chemicals to contact the windscreen.

Caution

Products such as window cleaning fluids, insect remover, rain repellent, scouring compounds, petrol or strong solvents such as alcohol, acetone, carbon tetrachloride, etc. will damage the windscreen.

Never allow these products to contact the windscreen.

Clean the windscreen with a solution of mild soap or detergent and cold water.

After cleaning, rinse well and then dry with a soft, lint-free cloth.

If the transparency of the windscreen is reduced by scratches or oxidation which cannot be removed, the windscreen must be replaced.

Care of Leather Products

We recommend that you periodically clean your leather products with a damp cloth and allow them to dry naturally at room temperature. This will maintain the appearance of the leather and ensure the long life of your product. Your Triumph leather product is a natural product and lack of care can result in damage and permanent wear. Follow these simple instructions and give your leather product the respect it deserves:

- Do not use household cleaning products, bleach, detergents containing bleach or any kind of solvent to clean your leather product.
- Do not immerse your leather product in water.
- Avoid direct heat from fires and radiators which can dry out and distort the leather.
- Do not leave your leather product in direct sunlight for prolonged periods of time.
- Do not dry your leather product by applying direct heat to it at any time.
- If your leather product does get wet, absorb any excess water with a soft clean cloth then leave the product to dry naturally at room temperature.

Cleaning and Storage

- Avoid exposure of your leather product to high levels of salt, for example sea/salt water or road surfaces that have been treated during the winter for ice and snow.
- If exposure to salt is unavoidable, clean your leather product immediately after each exposure using a damp cloth then leave the product to dry naturally at room temperature.
- Gently clean any minor marks with a damp cloth then leave the product to dry naturally at room temperature.
- Place your leather product in a fabric bag or cardboard box to protect it when in storage. Do not use a plastic bag.

Preparation for Storage

Clean and dry the entire vehicle thoroughly.

Fill the fuel tank with the correct grade of unleaded fuel and add a fuel stabiliser (if available), following the fuel stabiliser manufacturer's instructions.

Warning

Petrol is extremely flammable and can be explosive under certain conditions.

Turn the ignition switch off. Do not smoke.

Make sure the area is well ventilated and free from any source of flame or sparks; this includes any appliance with a pilot light.

Remove the spark plug from each cylinder and put several drops (5 ml) of engine oil into each cylinder. Cover the spark plug holes with a piece of cloth or rag. With the engine stop switch in the RUN position, push the starter button for a few seconds to coat the cylinder walls with oil. Install the spark plugs, tightening to **12 Nm**.

Change the engine oil and filter (see page **100**).

Check and if necessary correct the tyre pressures.

Set the motorcycle on a stand so that both wheels are raised off the ground. (If this cannot be done, put boards under the front and rear wheels to keep dampness away from the tyres.)

Spray rust inhibiting oil on all unpainted metal surfaces to prevent rusting. There are a variety of products on the market and your dealer will be able to offer you local advice. Prevent oil from getting on rubber parts, brake discs or in the brake calipers.

Make sure the cooling system is filled with a 50% mixture of coolant (noting that HD4X Hybrid OAT coolant, as supplied by Triumph, is premixed and requires no dilution) and distilled water solution (see page **102**).

Remove the battery, and store it where it will not be exposed to direct sunlight, moisture, or freezing temperatures. During storage it should be given a slow charge (one Ampere or less) approximately once every two weeks (see page **131**).

Store the motorcycle in a cool, dry area, away from sunlight, and with a minimum daily temperature variation.

Put a suitable porous cover over the motorcycle to keep dust and dirt from collecting on it. Avoid using plastic or similar non-breathable, coated materials that restrict air flow and allow heat and moisture to accumulate.

Preparation after Storage

Install the battery (if removed) (see page **134**).

If the motorcycle has been stored for more than four months, change the engine oil (see page **100**).

Check all the points listed in the Daily Safety Checks section.

Before starting the engine, remove the spark plugs from each cylinder.

Put the side stand down.

Crank the engine on the starter motor several times until the oil pressure light goes out.

Refit the spark plugs, tightening to **12 Nm**, and start the engine.

Check and if necessary correct the tyre pressures.

Clean the entire vehicle thoroughly.

Check the brakes for correct operation.

Test ride the motorcycle at low speeds.

Specifications

SPECIFICATIONS

Dimensions, Weights and Performance

A list of model specific dimensions, weights and performance figures is available from your authorised Triumph dealer, or on the Internet at www.triumph.co.uk.

Payload

Maximum Payload 196 kg (432 lbs)

Engine

Type In-line 3 Cylinder

Displacement 1,050 cc

Bore x Stroke 79 x 71.4 mm

Compression Ratio 12.25:1

Cylinder Numbering Left to Right

Cylinder Sequence Number 1 at Left

Firing Order 1-2-3

Starting System Electric Starter

Lubrication

Lubrication Forced Lubrication (wet sump)

Engine Oil Capacities

Dry Fill 3.5 litres

Oil/Filter Change 3.2 litres

Oil Change Only 3.0 litres

Cooling

Coolant Type Triumph HD4X Hybrid OAT Coolant

Coolant Capacity 2.4 litres

Water/Anti-freeze Ratio 50/50 (premixed as supplied by Triumph)

Thermostat Opens (nominal) 85°C

Fuel System

Type	Electronic Fuel Injection
Injectors	Solenoid Operated
Fuel Pump	Submerged Electric
Fuel Pressure (nominal)	3.5 bar

Fuel

Type	91 RON Unleaded
Tank Capacity	15.5 litres

Ignition

Ignition System	Digital Inductive
Electronic Rev Limiter (r/min)	9,500 (r/min)
Spark Plug	NGK CR9EIA-9
Spark Plug Gap	0.9 mm
Gap Tolerance	+0.00/-0.1 mm

Transmission

Transmission Type	6 Speed, Constant Mesh
Clutch Type	Wet, Multi-Plate
Final Drive Chain	RK 530 FXW, 108 Link
Primary Drive Ratio	1.75:1 (60/105)
Gear Ratios:	
Final Drive Ratio	2.389:1 (18/43)
1 st	2.733:1 (15/41)
2 nd	1.947:1 (19/37)
3 rd	1.545:1 (22/34)
4 th	1.292:1 (24/31)
5 th	1.154:1 (26/30)
6 th	1.037:1 (27/28)

Specifications

Warning

Use the recommended tyres **ONLY** in the combinations given. Do not mix tyres from different manufacturers or mix different specification tyres from the same manufacturers as this may result in loss of motorcycle control and an accident.

Approved Tyres

A list of approved tyres specific to these models is available from your authorised Triumph dealer, or on the Internet at www.triumph.co.uk.

Tyres

Tyre Pressures (Cold)

Front	2.35 bar (34 lb/in ²)
Rear	2.90 bar (42 lb/in ²)

Tyre Sizes

Front Size	120/70 ZR17
Rear Size	190/55 ZR17

Approved Tyres

Electrical Equipment

Alternator	12 Volt, 35 Amp
Battery	12 Volt, 12 Ah
Directional Indicator Lights	LED
Headlight	2 x 12 Volt, 60/55 Watt H4 Halogen
Rear Light	LED
License Plate Light	12 Volt, 5 Watt Bulb

Frame

Rake	23.0°
Trail	91 mm

Tightening Torques

Front Brake Fluid Reservoir Cap Retaining Screws	1 Nm
Fuel Tank Front Fixings	4 Nm
Fuel Tank Front Panel Fixings	2 Nm
Headlight Bracket Bolts	7 Nm
License Plate Bracket Fixing	2 Nm
Oil Filter	10 Nm
Oil Drain Plug	25 Nm
Rear Wheel Eccentric Clamp Bolt	55 Nm
Rider's Seat Fixings	9 Nm
Spark Plugs	12 Nm

Fluids and Lubrication

Bearings and Pivots	Grease to NLGI 2 Specification
Brake Fluid	DOT 4 Brake and Clutch Fluid
Coolant	Triumph HD4X Hybrid OAT Coolant
Drive Chain	Chain Spray suitable for O-Ring Chains
Engine Oil	Semi or fully synthetic 10W/40 or 10W/50 motorcycle engine oil which meets specification API SH (or higher) and JASO MA, such as Castrol Power 1 Racing 4T 10W-40 (fully synthetic) engine oil, sold as Castrol Power RS Racing 4T 10W-40 (fully synthetic) in some countries.

Index

INDEX

- A**
- Accessories..... 89
 - Anti-Lock Braking System (ABS)
 - Optimised Cornering ABS..... 84
- B**
- Battery..... 131
 - Charging..... 134
 - Discharge..... 133
 - Disposal..... 132
 - Installation..... 134
 - Maintenance..... 132
 - Removal..... 132
 - Storage..... 133
 - Brakes..... 111
 - Brake and Clutch Lever Adjusters..... 58
 - Brake Lever Adjuster..... 58, 59
 - Breaking in New Pads and Discs..... 112
 - Disc Brake Fluid..... 114
 - Fluid Level Inspection..... 114, 115
 - Front Brake Fluid Reservoir..... 114
 - Light Switches..... 115
 - Optimised Cornering ABS..... 84
 - Pad Wear Compensation..... 113
 - Rear Brake Fluid Reservoir..... 115
 - Wear Inspection..... 111
- C**
- Cleaning
 - After Washing..... 146
 - Aluminium Items - not Lacquered or Painted..... 147
 - Black Chrome Items..... 148
 - Care of Leather Products..... 149
 - Chrome and Stainless Steel..... 147
 - Drying..... 148
 - Exhaust System..... 148
 - Frequency of Cleaning..... 144
 - Gloss Paintwork..... 146
 - Matt Paintwork..... 146
 - Preparation for Washing..... 144
- Protecting..... 148
 - Seat Care..... 148
 - Washing..... 145
 - Washing the Exhaust..... 148
 - Where to be Careful..... 145
 - Windscreen..... 149
- Clutch**..... 107
 - Adjustment..... 107
 - Inspection..... 107

Clutch Lever
 - Clutch Lever Adjuster..... 60

Cooling System..... 102
 - Coolant Change..... 105
 - Corrosion Inhibitors..... 102, 103
 - Level Adjustment..... 104
 - Level Inspection..... 103
 - Specifications..... 152

Cruise Control
 - Activating..... 62
 - Adjusting the Set Speed..... 63
 - Cruise Control Adjust Button..... 56
 - Deactivating..... 63
 - Resuming the Set Speed..... 64

D

 - Direction Indicator Lights..... 141
 - Drive Chain..... 108
 - Free Movement Adjustment..... 109
 - Free Movement Inspection..... 109
 - Lubrication..... 108
 - Wear Inspection..... 111

E

 - Electrical Equipment..... 154
 - Engine
 - Moving Off..... 80
 - Serial Number..... 15
 - Specifications..... 152
 - Starting the Engine..... 78, 79
 - Stopping the Engine..... 77, 77
 - Engine Oil..... 99
 - Disposal of Oil and Filters..... 101

Oil and Filter Change	100	Smart Key	49
Oil Level Inspection	100	Switch/Steering Lock	53
Specification and Grade	101	Immobiliser	
Engine Start/Stop Switch		Indicator Light	21
QUICK START Position	54	Instruments	
RUN Position	54	Speedometer	26
STOP Position	54	Tachometer	26
F		K	
Fluids and Lubricants	155	Keyless Ignition	49
Frame	154	L	
Front Suspension		Left Handlebar Switches	56
Compression Damping Adjustment	123, 124	Direction Indicator Switch	57
Rebound Damping Adjustment	122, 123	High Beam Button	24, 57
Fuel	153	Horn Button	57
Filling the Fuel Tank	69	Joystick Button	57
Fuel Grade	67	MODE Button	57
Fuel Tank Cap	68	Licence Place Light	141
Refuelling	68	Loading	89
System Specifications	153	Lubrication Specifications	152
Fuel Tank		M	
Lowering	106	Maintenance	
Raising	105	Scheduled Maintenance	95
Fuses		Master Ignition Switch (if fitted)	51
Front Fuse Box	135	Mirrors	116
Fuse Boxes	135	Bar End Mirrors	117
Identification	135	P	
Main Fuse	136	Parking	86
Rear Fuse Box	136	Parts Identification	12
G		Passengers	89
Gears		R	
Changing Gears	80	Rear Light	141
H		Rear Suspension	
Headlights	137	Compression Damping Adjustment	125, 126
Bulb Replacement	139	Rebound Damping Adjustment	124, 125
Vertical Adjustment	138	Right Handlebar Switches	53, 55
High Speed Operation	87	Daytime Running Light (DRL) Switch	24
I		Daytime Running Lights (DRL) Switch	56
Ignition	153	Engine Stop Switch	55
Key	52	Hazard Switch	24
Keyless	49	Hazard Warning Lights	54, 55

Index

HOME Button	55	Information Tray - Coolant Temperature	35
Starter Button	55	Information Tray - Fuel Information	32
Running-In	74	Information Tray - Odometer	34
S		Information Tray - Overview	31
Safety		Information Tray - Screen Contrast	34
Daily Checks	75	Information Tray - Service Interval Announcement	34
Fuel and Exhaust Fumes	5	Information Tray - Style Options	35
Handlebars and Footrests	9	Information Tray - Trip Meter	35
Helmet and Clothing	6	Information Tray - Tyre Pressure Monitoring	33
Maintenance and Equipment	7	Information Tray - Warning Review	32
Motorcycle	5	Instrument Panel Layout	19
Parking	6	Instrument Panel Position Adjustment	49
Parts and Accessories	7	Main Menu - Bike Set Up - ABS	40
Riding	8	Main Menu - Bike Set Up - Direction Indicators	39
Seats	70, 70	Main Menu - Bike Set Up - Service	41
Passenger Seat Installation	71	Main Menu - Bike Set Up - Traction Control	41
Passenger Seat Removal	70	Main Menu - Display Set Up - Brightness	44
Rider's Seat Installation	72	Main Menu - Display Set Up - Language	45
Rider's Seat Removal	71	Main Menu - Display Set Up - Set Clock	46
Seat Care	70, 148	Main Menu - Display Set Up - Set Date	47
Seat Lock	70	Main Menu - Display Set Up - Set Units	46
Smart Key	49	Main Menu - Display Set Up - Themes and Styles	44
Operation	49	Main Menu - Display Set Up - Visible Tray	45
Stand	72	Main Menu - Reset to Defaults	48
Side Stand	72	Main Menu - Riding Mode Configuration	38
Steering		Main Menu - Riding Modes	37
Inspection	118	Main Menu - Trip 2 Enable/Disable	43
Steering Lock		Main Menu - Trip Setup	41
Steering Lock Button	54	Main Menu - Trip Setup - Automatic Reset	42
Storage		Main Menu - Trip Setup - Manual Reset	42
Preparation after Storage	151	Main Menu Overview	36
Preparation for Storage	150	Riding Mode Selection	29
Suspension		Riding Modes	28
Front Fork Inspection	119	Service Interval Announcement	27
Front Suspension Adjustment	122	TFT Display Navigation	20
Rear Suspension Adjustment	124	TFT Themes and Styles	20
Settings Chart	120, 121	Warning Lights	20
T		Throttle Control	60
TFT Digital Display		Tightening Torques	155
Ambient Air Temperature	27	Tool Kit	74
Fuel Gauge	27		
Gear Position Display	26		

Traction Control (TC)	
Disabled Warning Light.....	23
Indicator Light.....	22
Transmission Specifications.....	153
Triumph Shift Assist.....	81
Tyre Pressure Monitoring System (TPMS).....	64
Sensor Serial Number.....	66
Tyre Pressures.....	128
Tyres.....	3, 127
Inflation Pressures.....	154
Minimum Tread Depth.....	129
Replacement.....	129
Specifications.....	154
Tyre Inflation Pressures.....	127
Tyre Pressures.....	65
Tyre Wear.....	128
U	
Universal Serial Bus (USB) Socket.....	73
V	
Vehicle Identification Number.....	15
W	
Warnings.....	3
Maintenance.....	3
Owner's Handbook.....	4
Warning Label Locations.....	10, 11
Warning Labels.....	3
Warning Lights.....	21
Wheel Bearings	
Inspection.....	118

Smart Keyless System Approval Addendum

SMART KEYLESS SYSTEM APPROVAL ADDENDUM

Smart Keyless System Approval

US and Canada Only

The Smart Keyless system complies with part 15 of the Federal Communications Commission (FCC) rules and IC-RSS-210 Industry Canada. Operation is subject to the following conditions:

1. This device may not cause harmful interference.
2. This device must accept interference received, including interference that may cause undesired operation.

USA FCC ID: AQQ008

Canada IC: 10176A-008

Model No. A-0794G01

CAUTION: Risk of explosion if a battery is replaced by an incorrect type. Dispose of used batteries according to the instructions.

Under Industry Canada regulations, this radio transmitter may only operate using an antenna of a type and maximum (or lesser) gain approved for the transmitter by Industry Canada.

To reduce potential radio interference to other users, the antenna type and its gain should be so chosen that the Equivalent Isotropically Radiated Power (EIRP) is not more than that necessary for successful communication.

This device complies with Industry Canada license-exempt RSS standard(s). Operation is subject to the following two conditions:

1. this device may not cause interference, and
2. this device must accept any interference, including interference that may cause undesired operation of the device.

Smart Keyless System Approval Addendum

Smart Key Battery Replacement

Warning

There is a risk of explosion if an incorrect battery is used.

Always make sure that the correct battery size and type is used.

Warning

Batteries contain harmful materials.

Always keep batteries out of the reach of infants and young children to prevent them being swallowed.

If swallowed, consult a doctor immediately.

To replace the smart key battery:

- Make sure that the smart key is in passive mode (red LED).
- Remove the battery cover fixing using a 1.5 mm AF Allen key.
- Remove the battery cover.
- Remove the battery, noting its orientation.
- Insert a new 3 Volt CR2032 Lithium battery.
- Replace the battery cover making sure that it aligns correctly.
- Refit the battery cover fixing and tighten to 0.3 Nm.

Battery Disposal

The used battery must be handed to a recycling agent who will make sure that the dangerous substances from which the battery is manufactured do not pollute the environment.

Smart Keyless System Approval Addendum

This page intentionally left blank